

Proposal for HOTWORX Operational Adjustments

Thank you for the opportunity to discuss the conditions for HOTWORX, a 24-hour infrared sauna fitness studio. We aim to operate according to the national HOTWORX model, which includes round-the-clock access for members. I understand there is an ordinance in place allowing gyms to operate 24 hours unmanned, except when saunas are involved. As saunas are the core equipment in our facility, we recognize the need for special conditions and have implemented robust safety measures that align with this requirement. Below, I propose modifications to the current conditions to reflect our specific operations.

Current Condition 1.

At least one employee or manager, trained and qualified in first aid and CPR, shall be on duty at all times when the licensed premises are in operation or open to the public.

Proposed Update:

HOTWORX provides 24-hour security through surveillance systems, and a personal emergency response system is available for members who choose to wear emergency buttons, allowing them to directly contact emergency services if needed. The local police department also has 24-hour access to our security cameras. Our staff is scheduled during peak traffic hours, ensuring trained personnel are present during busy times. Additionally, when members sign up, they receive training on the safe use of all equipment, including our saunas, and sign a waiver. This system ensures the safety of members while still providing the flexibility of 24-hour access.

Current Condition 2:

No exercise equipment shall be used unless there is an employee on duty who is trained to advise on the safe use of the equipment.

Proposed Update:

HOTWORX saunas are the primary equipment, and members are trained on safe use during their initial sign-up. Virtual, instructor-led workout sessions guide members 24/7, with safety instructions included in each session. Staff are present during peak hours for additional assistance. This combination of virtual guidance and initial training ensures member safety even when staff are not on-site.

Current Condition 3:

The licensee agrees to ensure that only registered members are permitted access to the facility during non-office hours, and non-members may access the space only during office hours.

Proposed Confirmation:

We strictly enforce this policy, using an advanced entry system to ensure only registered members can access the facility during non-staffed hours. Non-members can only visit during staffed hours for tours or information. This entry system complies with the business plan on file with the Department of Safety and Inspections.

Labels 1 to 5 6 to 10 11 to 15 16 to 20 21 to 25 26 to 30 31 to

| Date | Day | Total Count | 12am | 1am | 2am | 3am | 4am | 5am | 6am | 7am | 8am | 9am | 10am | 11am | 12pm | 1pm | 2pm | 3pm | 4pm | 5pm | 6pm | 7pm | 8pm | 9pm | 10pm | 11pm |
|--------|-----------|-------------|------|-----|-----|-----|-----|-----|-----|-----|-----|-----|------|------|------|-----|-----|-----|-----|-----|-----|-----|-----|-----|------|------|
| 01-May | Monday | 149 | 0 | 0 | 1 | 1 | 1 | 3 | 3 | 5 | 6 | 6 | 3 | 10 | 3 | 2 | 4 | 3 | 10 | 10 | 10 | 6 | 3 | 5 | 0 | 0 |
| 02-May | Tuesday | 140 | 0 | 0 | 1 | 1 | 2 | 5 | 5 | 6 | 6 | 6 | 6 | 9 | 6 | 1 | 4 | 9 | 13 | 9 | 13 | 6 | 3 | 7 | 1 | 0 |
| 03-May | Wednesday | 127 | 0 | 0 | 0 | 0 | 0 | 0 | 5 | 6 | 4 | 7 | 4 | 7 | 4 | 0 | 3 | 6 | 8 | 15 | 15 | 4 | 10 | 4 | 1 | 0 |
| 04-May | Thursday | 135 | 0 | 0 | 0 | 0 | 0 | 2 | 10 | 7 | 10 | 9 | 5 | 8 | 6 | 5 | 9 | 8 | 11 | 12 | 15 | 5 | 6 | 4 | 0 | 0 |
| 05-May | Friday | 97 | 0 | 0 | 0 | 0 | 3 | 2 | 5 | 6 | 6 | 6 | 4 | 6 | 6 | 3 | 1 | 8 | 8 | 5 | 9 | 4 | 6 | 3 | 0 | 0 |
| 06-May | Saturday | 80 | 2 | 0 | 0 | 0 | 1 | 3 | 0 | 4 | 6 | 15 | 9 | 7 | 7 | 6 | 2 | 5 | 0 | 1 | 1 | 3 | 1 | 1 | 0 | 0 |
| 07-May | Sunday | 59 | 1 | 0 | 0 | 0 | 0 | 1 | 0 | 0 | 0 | 6 | 6 | 15 | 8 | 9 | 7 | 4 | 1 | 4 | 3 | 2 | 4 | 0 | 0 | 0 |
| 08-May | Monday | 145 | 0 | 0 | 0 | 0 | 2 | 6 | 8 | 6 | 6 | 9 | 7 | 6 | 6 | 4 | 4 | 9 | 11 | 12 | 10 | 8 | 6 | 5 | 2 | 0 |
| 08-May | Monday | 145 | 0 | 0 | 0 | 0 | 2 | 6 | 8 | 6 | 6 | 9 | 7 | 6 | 6 | 4 | 4 | 9 | 11 | 12 | 10 | 8 | 6 | 5 | 2 | 0 |
| 09-May | Tuesday | 129 | 0 | 0 | 0 | 0 | 0 | 3 | 4 | 2 | 2 | 2 | 1 | 5 | 2 | 1 | 5 | 6 | 4 | 8 | 13 | 8 | 4 | 6 | 1 | 0 |
| 10-May | Wednesday | 134 | 0 | 0 | 0 | 0 | 1 | 5 | 2 | 9 | 10 | 10 | 10 | 3 | 10 | 4 | 2 | 8 | 4 | 10 | 10 | 8 | 7 | 9 | 3 | 0 |
| 11-May | Thursday | 90 | 0 | 0 | 0 | 0 | 2 | 6 | 0 | 7 | 7 | 2 | 4 | 6 | 4 | 2 | 1 | 6 | 2 | 6 | 8 | 8 | 5 | 7 | 0 | 0 |
| 12-May | Friday | 71 | 0 | 0 | 0 | 0 | 2 | 2 | 7 | 9 | 5 | 8 | 4 | 4 | 3 | 1 | 2 | 6 | 7 | 6 | 1 | 6 | 2 | 2 | 0 | 0 |
| 13-May | Saturday | 46 | 0 | 0 | 0 | 0 | 0 | 1 | 1 | 3 | 6 | 9 | 1 | 1 | 4 | 3 | 5 | 2 | 5 | 0 | 0 | 5 | 0 | 0 | 0 | 0 |
| 14-May | Sunday | 70 | 2 | 0 | 0 | 0 | 0 | 1 | 0 | 2 | 5 | 2 | 5 | 3 | 3 | 3 | 4 | 1 | 8 | 8 | 3 | 2 | 8 | 4 | 0 | 0 |
| 15-May | Monday | 127 | 0 | 0 | 0 | 0 | 4 | 6 | 4 | 7 | 6 | 6 | 4 | 4 | 8 | 5 | 3 | 3 | 3 | 3 | 10 | 10 | 7 | 7 | 2 | 0 |
| 15-May | Monday | 127 | 0 | 0 | 0 | 0 | 4 | 6 | 4 | 7 | 6 | 6 | 4 | 4 | 8 | 5 | 3 | 3 | 3 | 3 | 10 | 10 | 7 | 7 | 2 | 0 |
| 16-May | Tuesday | 127 | 0 | 0 | 0 | 0 | 0 | 2 | 4 | 2 | 7 | 7 | 7 | 2 | 2 | 2 | 6 | 6 | 12 | 12 | 6 | 3 | 3 | 3 | 0 | 0 |
| 17-May | Wednesday | 135 | 0 | 0 | 0 | 0 | 4 | 4 | 8 | 11 | 8 | 8 | 3 | 3 | 3 | 5 | 1 | 1 | 10 | 10 | 10 | 10 | 5 | 1 | 3 | 1 |
| 18-May | Thursday | 85 | 0 | 0 | 0 | 0 | 0 | 4 | 8 | 4 | 3 | 3 | 3 | 7 | 7 | 4 | 4 | 10 | 9 | 6 | 10 | 10 | 0 | 0 | 0 | 0 |
| 19-May | Friday | 82 | 0 | 0 | 0 | 0 | 2 | 3 | 6 | 6 | 6 | 8 | 9 | 2 | 2 | 2 | 0 | 5 | 8 | 3 | 7 | 4 | 5 | 3 | 0 | 0 |
| 20-May | Saturday | 80 | 0 | 0 | 0 | 0 | 0 | 0 | 0 | 0 | 4 | 5 | 10 | 3 | 3 | 3 | 4 | 3 | 3 | 5 | 5 | 1 | 2 | 2 | 0 | 0 |
| 21-May | Sunday | 54 | 0 | 0 | 0 | 0 | 0 | 0 | 0 | 0 | 5 | 1 | 1 | 3 | 3 | 6 | 4 | 7 | 5 | 5 | 2 | 1 | 0 | 0 | 0 | 0 |
| 22-May | Monday | 119 | 0 | 0 | 0 | 0 | 0 | 0 | 0 | 0 | 0 | 0 | 0 | 0 | 0 | 0 | 0 | 0 | 0 | 0 | 0 | 0 | 0 | 0 | 0 | 0 |

The Gaston & Davis HOTWORX Studio St. Paul, MN

DRAWING INDEX

- 1- COVER SHEET
- 2- EXISTING AND PROPOSED PLAN
- 3- WALL SECTIONS AND DETAILS
- 4- ELECTRICAL PLAN
- 5- LIGHTING PLAN
- 6- INTERIOR ELEVATIONS
- 7- FLOORING PLAN
- 8- SECURITY PLAN

NOTE:

DO NOT REMOVE SECURITY PACKAGE SHEET FROM ARCHITECTURAL DRAWINGS OR IT WILL CAUSE DELAYS AND / OR ADDED EXPENSES

VICINITY MAP

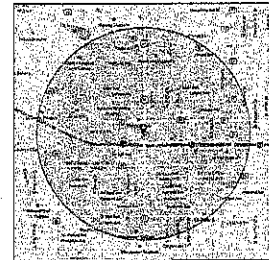

ALL DRAWINGS ARE PROVIDED FOR USE OF STUDIO OWNER FOR THE PURPOSE OF SPACE ALLOCATION. HOTWORX LLC IS NOT AN ARCHITECTURAL OR MECHANICAL FIRM AND CLAIMS NO RESPONSIBILITY IN SUPPLYING OWNER W/ PERMIT PLANS. ALL MECHANICAL & ELECTRICAL SPECIFICATIONS SHOULD BE DONE BY A LICENSED PRACTITIONER. DO NOT UNDER ANY CIRCUMSTANCES SCALE DRAWINGS. FIELD VERIFY ALL MEASUREMENTS AT THE SITE BEFORE EXECUTION AND NOTIFY HOTWORX OF ANY DISCREPANCIES BETWEEN THESE PLANS & ACTUAL CONDITIONS.

- * ALL DIMENSIONS ARE CRITICAL.
- * ALL ELECTRICAL, MECHANICAL & PLUMBING WORK TO BE BY LICENSED PRACTITIONERS.
- * ALL WALLS & STRUCTURAL CHANGES BY GENERAL CONTRACTOR MUST BE NOTIFIED TO HOTWORX LLC.

HOTWORX

FOR THE PURPOSES OF SPACE ALLOCATION, HOTWORX LLC IS NOT AN ARCHITECTURAL OR MECHANICAL FIRM AND CLAIMS NO RESPONSIBILITY IN SUPPLYING OWNER WITH PERMIT PLANS. ALL MECHANICAL & ELECTRICAL SPECIFICATIONS SHOULD BE DONE BY A LICENSED PRACTITIONER. DO NOT UNDER ANY CIRCUMSTANCES SCALE DRAWINGS. FIELD VERIFY ALL MEASUREMENTS AT THE SITE BEFORE EXECUTION AND NOTIFY HOTWORX OF ANY DISCREPANCIES BETWEEN THESE PLANS & ACTUAL CONDITIONS.

| REVISION | |
|----------|-------|
| DATE | NOTES |
| | |
| | |
| | |

CONTACTS
Contact: Development Team
HOTWORX Foundation
development@hotworx.com

PROJECT
Nelson-Gordon & Hall, Paces
Development
421 Exchange Ave, N
St. Paul, MN 55104
02-28-2024

HOTWORX

SCALE
NOT TO SCALE
DATE
02/28/2024
DRAWN BY
DEBBIE ?
DRAWING TITLE

COVER SHEET

SHEET NO.
1 OF 8

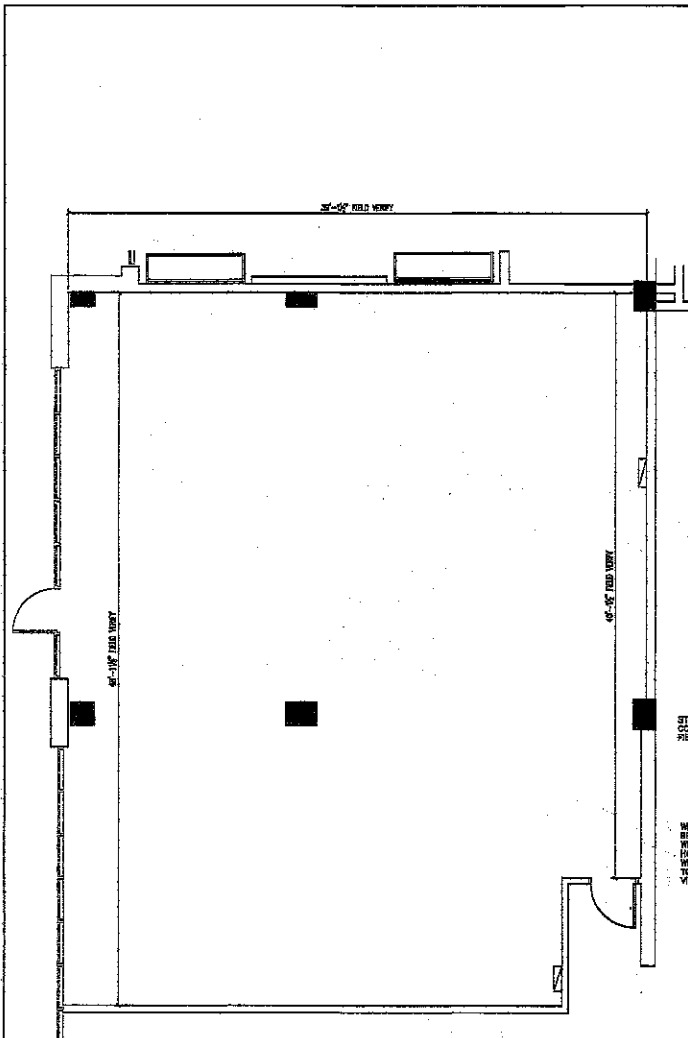

EXISTING FLOORPLAN
SCALE 1/4"=1'-0"

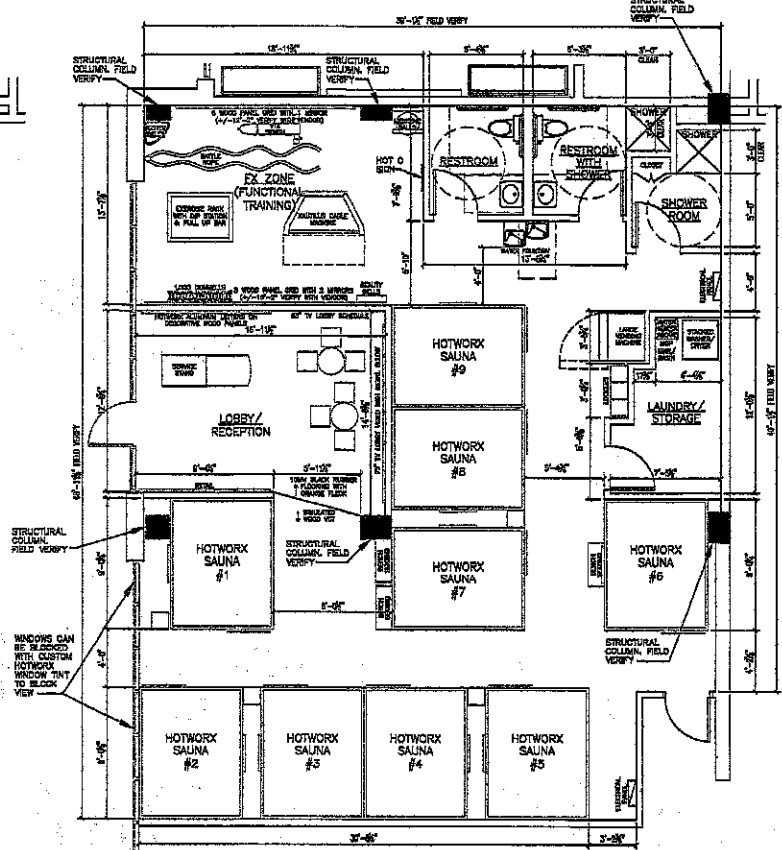

PROPOSED FLOORPLAN
SCALE 1/4"=1'-0"

GENERAL NOTES

1. ALL WORK SHALL CONFORM TO CITY OF LOCATION, FEDERAL, STATE AND LOCAL CODES.
 2. THE CONTRACTOR SHALL OBTAIN ALL NECESSARY PERMITS AND SHALL PAY ALL REQUIRED FEES FOR THIS WORK.
 3. THE CONTRACTOR SHALL FIELD VERIFY EXISTING CONDITIONS AND REPORT TO HOTWORX IN WRITING ANY DISCREPANCIES IMMEDIATELY UPON DISCOVERY. DO NOT UNDER ANY CIRCUMSTANCES SCALE DRAWINGS.
 4. UNLESS OTHERWISE NOTED ALL TELEPHONE, ELECTRICAL, OUTLETS SHALL BE LOCATED 18" ABOVE THE FINISHED FLOOR.
 5. UNLESS OTHERWISE NOTED, DIMENSIONS FOR ALL NEW WORK ARE MEASURED FROM FACE OF FINISHED WALL. DIMENSIONS REFERRING TO EXISTING WORK ARE MEASURED FROM FACE OF EXISTING FINISH.
 6. EXISTING WALLS TO REMAIN SHALL BE REPAIRED AND REFINISHED AS REQUIRED TO PROVIDE A SMOOTH AND UNIFORM SURFACE FOR THE APPLICATION OF NEWLY INDICATED FINISHES.
 7. THE CONTRACTOR SHALL, AT ALL TIMES, KEEP THE PREMISES FREE FROM ACCUMULATION OF WASTE MATERIALS OR RUBBISH CAUSED BY THE WORK. AT THE COMPLETION OF THE WORK CONTRACTOR SHALL REMOVE ALL WASTE MATERIALS AND RUBBISH FROM AND ABOUT THE PROJECT AS WELL AS ALL TOOLS, CONSTRUCTION EQUIPMENT AND MACHINERY.
 8. ALL SURPLUS EQUIPMENT AND MATERIALS ARE THE PROPERTY OF THE OWNER. THE CONTRACTOR SHALL COORDINATE WITH THE OWNER THE DISPOSAL OF ANY AND ALL SURPLUSES.
 9. ALL WORK SHALL BE PERFORMED IN A MANNER AND AT A TIME WHICH LEAST DISRUPTS THE BUSINESS PROCEDURE OF ANY PRESSIBLE AREAS OR NEIGHBORING BUSINESSES.
 10. THE CONTRACTOR SHALL INDIVIDUALLY WARRANT FOR THE ONE YEAR ALL MATERIALS AND WORKMANSHIP EXCEPT OTHERWISE ADVISED.
 11. ELECTRICAL, MECHANICAL, & PLUMBING SHALL BE BIDDER DESIGNED.
 12. RESTROOM TO BE HANDICAP ACCESSIBLE AS REQUIRED BY ADA REGULATIONS.
 13. GENERAL CONTRACTOR TO PROVIDE PROPER VENT FOR CLOTHES DRYER.
 14. ELECTRICIAN TO PROVIDE ALL EXIT & EMERGENCY LIGHTING AS REQUIRED BY CODE.
 15. INTERIOR WALL WILL BE MEDIA OR WOOD STUD AND SHEETROCK TYPE. ARCHITECT AND GENERAL CONTRACTOR TO VERIFY ALL DIMENSIONS ON JOB.
 16. PROVIDE FLOOR DRAIN IN STORAGE/LAUNDRY AND RESTROOMS IF REQUIRED.
 17. PROVIDE AIR CIRCULATION WHERE TELECOMMUNICATION DATA AND SECURITY EQUIPMENT ARE LOCATED.
- *THIS DRAWING IS APPROVED CONTINGENT UPON THE FOLLOWING:
 -THE DIMENSIONS ARE TRUE AND ACCURATE.
 -THE RESTROOMS AND HALLWAYS MEET REQUIRED ADA CODE AND SAFETY STANDARDS

- *ALL DRAWINGS ARE PROVIDED FOR USE OF STUDIO OWNER FOR THE PURPOSE OF SPACE ALLOCATION. *HOTWORX LLC IS NOT AN ARCHITECTURAL OR MECHANICAL FIRM AND CLAIMS NO RESPONSIBILITY IN SUPPLYING OWNER W/ PERMIT PLANS.
- *ALL MECHANICAL & ELECTRICAL SPECIFICATIONS SHOULD BE DONE BY A LICENSED PRACTITIONER. DO NOT UNDER ANY CIRCUMSTANCES SCALE DRAWINGS. FIELD VERIFY ALL MEASUREMENTS AT THE SITE BEFORE EXECUTION AND NOTIFY HOTWORX OF ANY DISCREPANCIES BETWEEN THESE PLANS & ACTUAL CONDITIONS.
- * ALL DIMENSIONS ARE CRITICAL.
- * ALL ELECTRICAL, MECHANICAL & PLUMBING WORK TO BE BY LICENSED PRACTITIONERS.
- * ALL WALLS & STRUCTURAL CHANGES BY GENERAL CONTRACTOR MUST BE NOTIFIED TO HOTWORX.

HOTWORX

ALL WORK SHALL BE DONE IN ACCORDANCE WITH THE CITY OF LOCATION, FEDERAL, STATE AND LOCAL CODES. THE CONTRACTOR SHALL OBTAIN ALL NECESSARY PERMITS AND SHALL PAY ALL REQUIRED FEES FOR THIS WORK. THE CONTRACTOR SHALL FIELD VERIFY EXISTING CONDITIONS AND REPORT TO HOTWORX IN WRITING ANY DISCREPANCIES IMMEDIATELY UPON DISCOVERY. DO NOT UNDER ANY CIRCUMSTANCES SCALE DRAWINGS. UNLESS OTHERWISE NOTED ALL TELEPHONE, ELECTRICAL, OUTLETS SHALL BE LOCATED 18" ABOVE THE FINISHED FLOOR. UNLESS OTHERWISE NOTED, DIMENSIONS FOR ALL NEW WORK ARE MEASURED FROM FACE OF FINISHED WALL. DIMENSIONS REFERRING TO EXISTING WORK ARE MEASURED FROM FACE OF EXISTING FINISH. EXISTING WALLS TO REMAIN SHALL BE REPAIRED AND REFINISHED AS REQUIRED TO PROVIDE A SMOOTH AND UNIFORM SURFACE FOR THE APPLICATION OF NEWLY INDICATED FINISHES. THE CONTRACTOR SHALL, AT ALL TIMES, KEEP THE PREMISES FREE FROM ACCUMULATION OF WASTE MATERIALS OR RUBBISH CAUSED BY THE WORK. AT THE COMPLETION OF THE WORK CONTRACTOR SHALL REMOVE ALL WASTE MATERIALS AND RUBBISH FROM AND ABOUT THE PROJECT AS WELL AS ALL TOOLS, CONSTRUCTION EQUIPMENT AND MACHINERY. ALL SURPLUS EQUIPMENT AND MATERIALS ARE THE PROPERTY OF THE OWNER. THE CONTRACTOR SHALL COORDINATE WITH THE OWNER THE DISPOSAL OF ANY AND ALL SURPLUSES. ALL WORK SHALL BE PERFORMED IN A MANNER AND AT A TIME WHICH LEAST DISRUPTS THE BUSINESS PROCEDURE OF ANY PRESSIBLE AREAS OR NEIGHBORING BUSINESSES. THE CONTRACTOR SHALL INDIVIDUALLY WARRANT FOR THE ONE YEAR ALL MATERIALS AND WORKMANSHIP EXCEPT OTHERWISE ADVISED. ELECTRICAL, MECHANICAL, & PLUMBING SHALL BE BIDDER DESIGNED. RESTROOM TO BE HANDICAP ACCESSIBLE AS REQUIRED BY ADA REGULATIONS. GENERAL CONTRACTOR TO PROVIDE PROPER VENT FOR CLOTHES DRYER. ELECTRICIAN TO PROVIDE ALL EXIT & EMERGENCY LIGHTING AS REQUIRED BY CODE. INTERIOR WALL WILL BE MEDIA OR WOOD STUD AND SHEETROCK TYPE. ARCHITECT AND GENERAL CONTRACTOR TO VERIFY ALL DIMENSIONS ON JOB. PROVIDE FLOOR DRAIN IN STORAGE/LAUNDRY AND RESTROOMS IF REQUIRED. PROVIDE AIR CIRCULATION WHERE TELECOMMUNICATION DATA AND SECURITY EQUIPMENT ARE LOCATED.

| REVISION | |
|----------|----------|
| DATE | INITIALS |
| | |
| | |
| | |

CONTACTS
Contact Development Team
HOTWORX Franchising
development@hotworx.net

PROJECT
Nashville Gordon & Alesh, Owners
HOTWORX STUDIO - ANCO092
1717 17th Ave NW, Suite 104
Atlanta, GA 30318
02-28-2024

HOTWORX

| | |
|---------------|-------------------------------------|
| SCALE | 1/4" = 1'-0" |
| DATE | 02/28/2024 |
| DRAWN BY | DEBBIE T |
| DRAWING TITLE | EXISTING PROPOSED CONSTRUCTION PLAN |
| SHEET NO. | 2 OF 5 |



LOBBY FURNITURE:

—RED METAL INDOOR/OUTDOOR CHAIR WITH ARMS
(CH-31270-RED-GG)— NEED 3 FOR EACH TABLE.
ORDER FROM BIZCHAIR.COM

—TABLES WILL BE PROVIDED IN THE INTERIOR BRANDING
COMPONENTS PACKAGE

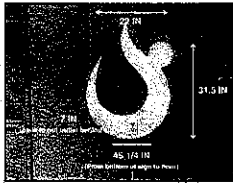

HOT-O SIGN:
*MOUNT HOT-O SIGN AT 46.25"
A.F.F. TO BOTTOM OF SIGN.
REQUIRES ELECTRICAL OUTLET
LOCATED BEHIND SIGN.

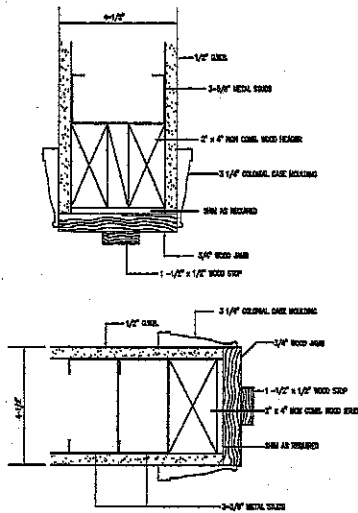

(A) TYPICAL WOOD DOOR HEADER/JAMBS

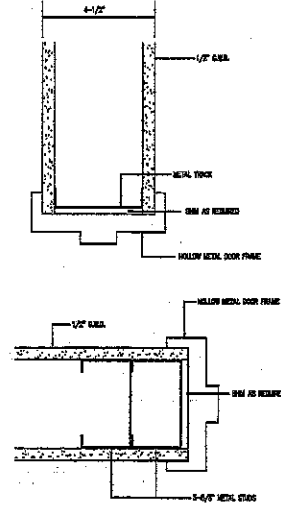

(B) TYPICAL METAL DOOR HEADER/JAMBS

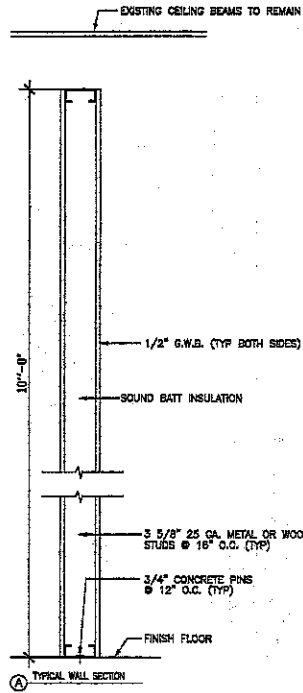

(A) TYPICAL WALL SECTION

Paint Schedule

General:

- *Contractor shall provide a minimum of one primer coat, and two finish coats.
- *All wall paint shall be Interior Latex - Satin finish
- *All ceiling paint shall be Interior Latex - Satin finish
- *Ceiling to be painted BLACK
- *All doors, door frames and trim work shall be Interior Latex - Semi-Gloss
- *All paint shall be Sherwin Williams brand, no substitutes will be accepted.
- *Prepare all surfaces prior to painting

Product Type:

SW7072 "ONLINE" - Demising walls, Front wall and Rear wall from finish floor up to ceiling. (Light Gray)

SW7074 "SOFTWARE" - Interior walls from floor to ceiling and interior of restrooms. (Dark Gray)

SW888 "REAL RED" - Interior Doors and Door Frames and any Exposed HVAC Systems/Ductwork.

Paint all surface mounted conduit, pipes, columns, etc. to match the color of the wall.

Block paint for Ceiling and Ceiling Tiles.

| ITEM | G.C. | | OWNER | | REMARKS |
|--|-------|------|-------|--------|---------|
| | PLUMB | INST | PLUMB | FINISH | |
| DEMOLITION | X | X | | | |
| ELECTRICAL SERVICE: EXTERIOR METER SECTION, INTERIOR LOAD CENTER, NECESSARY WIRING, CIRCUITERS, & SWITCHES | X | X | | | |
| LIGHTING FIXTURES (CEILING) | | X | X | | |
| HVAC SYSTEM(S) | X | X | | | |
| PLUMBING | X | X | | | |
| WATER PROOF | X | X | | | |
| RESTROOM FIXTURES & FLOORING | X | X | | | |
| FLOOR CEILING SYSTEM(S) IF APPLICABLE | X | X | | | |
| PAINTING OF INTERIOR WALLS, DEMISING WALLS, DOORS, AND CEILING | X | X | | | |
| FLOORING (EXCEPT RESTROOMS) | | | X | X | |
| INTERIOR WALLS & DOORS | X | X | | | |
| METAL COMPONENTS/ FIXTURES | | | X | X | |
| SERVICE STAND | | | X | X | |
| FRAMES FOR NETWORK AND SCHEDULE | | | X | X | |
| BANISCHORS AND TRIM | X | X | | | |
| STORAGE CABINETS AND BENCH SEATING | | | X | X | |
| WASHER & DRYER | | | X | X | |
| WATER FEEDLINES | X | X | | | |
| CONVEYER EQUIPMENT, PDS | | | X | X | |
| EXTERIOR/ INTERIOR SIGNAGE PACKAGE | | | X | X | |
| FLAT SCREEN TELEVISIONS | | | X | X | |
| HOTWORK SIGNAGE *** WILL NEED ELECTRICAL TO HARDWIRE UNITS AFTER INSTALL *** | | | X | X | |
| CLEAN-UP & PUMPS/TEST FEES | X | X | | | |

*1- EXTERIOR SERVICE TO BE INSTALLED BY LOCAL SIGN INSTALL CO. ELECTRICIAN WILL NEED TO BE ON SITE IN ORDER TO COMPLETE SIGN INSTALL. ELECTRICAL CIRCUIT MUST BE IN PLACE. PROVIDED BY GC.

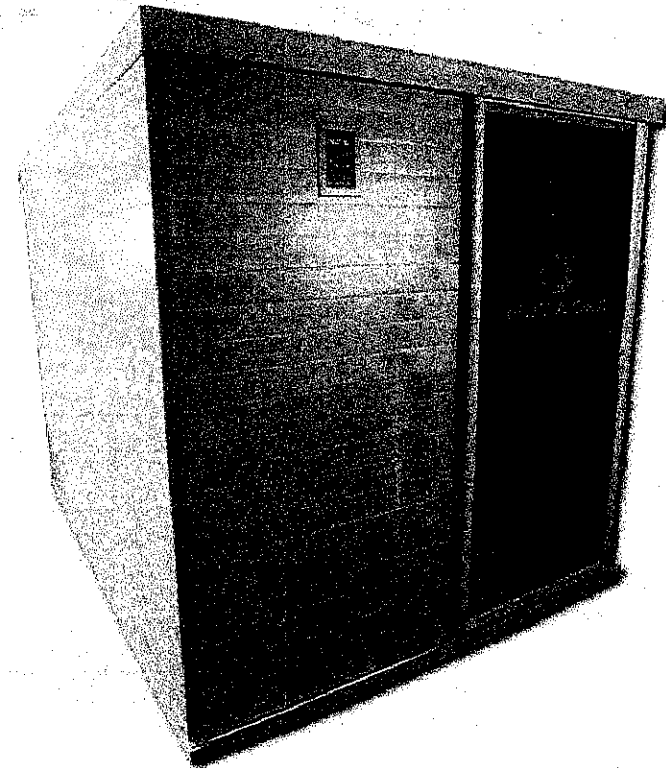

ALL WORK TO BE COMPLETED BY CONTRACTOR BEFORE THE END OF EACH WORKDAY. ALL WORK SHALL BE COMPLETED WITHIN THE SPECIFIED TIME FRAME. ALL WORK SHALL BE COMPLETED WITHIN THE SPECIFIED TIME FRAME. ALL WORK SHALL BE COMPLETED WITHIN THE SPECIFIED TIME FRAME.

| REVISION | |
|----------|-------|
| DATE | INFL. |
| | |
| | |

CONTACTS
Contact: Development Team
HOTWORK Production
development@hotwork.com

PROJECT
HOTWORK SIGNAGE - INDOOR
400 S. 1st Ave. N
St. Paul, MN 55104
02-28-2024



SCALE
NOT TO SCALE
DATE
02/28/2024
DRAWN BY
DEBBIE T.
DRAWING
TITLE

DETAILS & SCHEDULES

SHEET NO.
3 OF 8

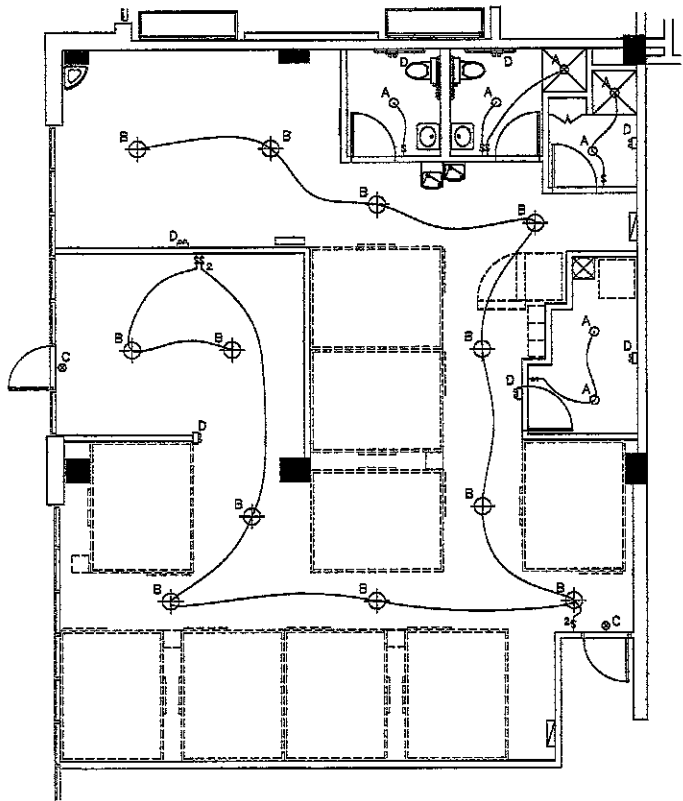

PROPOSED LIGHTING PLAN
SCALE 1/4"=1'-0"

LIGHTING SCHEDULE

- ⊙ A 6" LED RECESSED DOWN LIGHT
- ⊕ B HOTWORX FIXTURE: 60W LED UFO HIGH BAY LIGHT 8800LM 5000K IP65 WATERPROOF INDUSTRIAL WAREHOUSE HANGING LIGHT BY HYKOLITY. OPTIMAL HEIGHT 144" A.F.F.
- ⊙ C LED EXIT SIGN
- ⊕ D EMERGENCY LIGHT

NOTES:

- **WHEN ORDERING YOUR LIGHTING PACKAGE IT IS CRITICAL TO SPECIFY CEILING HEIGHT AND TYPE WITH LIGHTING VENDOR.
- **ELECTRICIAN TO PROVIDE ALL EXIT & EMERGENCY LIGHTING AS REQUIRED BY CODE.
- **ANY 2'X2' OR 2'X4 LIGHTING FIXTURES TO BE REMOVED
- **UFO LIGHTS (FIXTURE "B") TO BE HUNG BY CHAIN AT 12" AFF IF POSSIBLE
- **THE UFO LIGHTS (FIXTURE "B") COME AS PART OF THE INTERIOR BRANDING PACKAGE FROM CINEMATION DESIGN BUT YOU WILL NEED YOUR ELECTRICIAN TO HANG THEM. PLEASE CONTACT JOE MILLER AT CINEMATION DESIGN (817)-217-8241, WHEN YOU ARE READY FOR YOUR LIGHTS.

HOTWORX FIXTURE TYPE "B"

60W LED UFO HIGH BAY LIGHT 8800LM 5000K IP65 WATERPROOF INDUSTRIAL WAREHOUSE HANGING LIGHT BY HYKOLITY
OPTIMAL HEIGHT - 144" AFF



HOTWORX

ALL DRAWINGS ARE THE PROPERTY OF CINEMATION DESIGN. NO PART OF THIS DRAWING IS TO BE REPRODUCED OR TRANSMITTED IN ANY FORM OR BY ANY MEANS, ELECTRONIC OR MECHANICAL, INCLUDING PHOTOCOPYING, RECORDING, OR BY ANY INFORMATION STORAGE AND RETRIEVAL SYSTEM. WITHOUT THE WRITTEN PERMISSION OF CINEMATION DESIGN. ALL RIGHTS RESERVED.

CINEMATION DESIGN, INC. 4115 W. 14TH AVENUE, SUITE 100, DENVER, CO 80202
TEL: (303) 733-1111 FAX: (303) 733-1112
WWW.CINEMATIONDESIGN.COM

| REVISION | |
|----------|----------|
| DATE | INITIALS |
| | |
| | |
| | |

CONTACTS
Contact: Projectors: Tom
HOTWORX, Frankford
development@hotworx.com

PROJECT
Natalie Gosselin & Matt Davis
HOTWORX STUDIO - ANCO072
4115 W. 14th Ave. N
St. Paul, MN 55104
02-28-2024

HOTWORX

| | |
|---------------|------------------------|
| SCALE | 1/4" = 1'-0" |
| DATE | 02/28/2024 |
| DRAWN BY | DEBBIE T. |
| DRAWING TITLE | PROPOSED LIGHTING PLAN |
| SHEET NO. | 5 OF 8 |

NOTE: INTERNET, PHONE AND POWER TO SERVICE STAND TO BE RECESSED IN SLAB. COORDINATE LOCATION OF SERVICE STATION WITH OWNER PRIOR TO LOCATION OF RECESSED OUTLETS

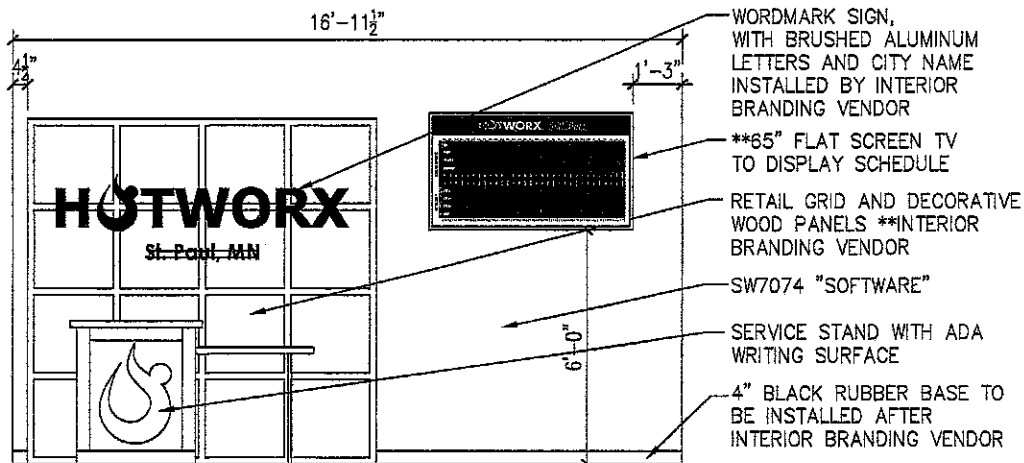

(A)- Service stand wall elevation

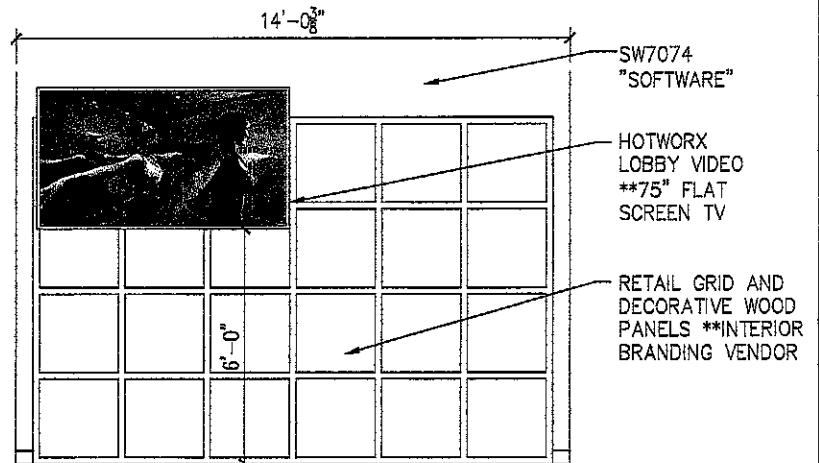

(B)- Retail wall elevation

NOTE: ELECTRICAL OUTLET TO BE LOCATED BEHIND FLAT SCREEN TV. COORDINATE WITH BRANDING VENDOR OF CHOICE.

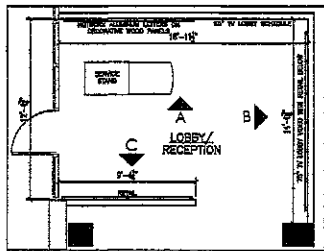

Paint Schedule

General:

- *Contractor shall provide a minimum of one primer coat, and two finish coats.
- *All wall paint shall be Interior Latex - Satin finish
- *All ceiling paint shall be Interior Latex - Satin finish
- *Ceiling to be painted BLACK
- *All doors, door frames and trim work shall be Interior Latex - Semi-Gloss
- *All paint shall be Sherwin Williams brand, no substitutes will be accepted.
- *Prepare all surfaces prior to painting

Product Type:

SW2022 "ONLINE" - Demolish walls, Front wall and Rear wall from finish floor up to ceiling. (Light Gray)

SW7074 "SOFTWARE" - Interior walls from floor to ceiling and interior of restrooms. (Dark Gray)

SW888 "REAL SET" - Interior Doors and Door Frames and any Exposed HVAC Systems/Ductwork

Paint all surface mounted conduit, pipes, columns, etc. to match the color of the wall.

Black paint for Ceiling and Ceiling Tiles.

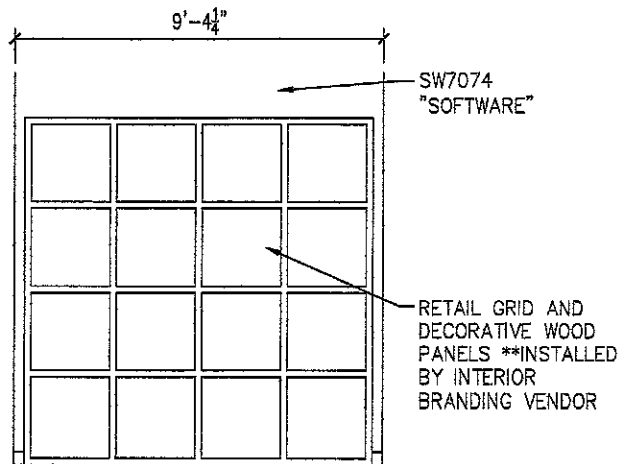

(C)- Retail wall elevation

NOTE:

ELEVATIONS ARE REPRESENTATIONAL OF PROPOSED LAY-OUT.

CONTRACTOR/FRANCHISEE TO VERIFY WITH BRANDING VENDOR OF CHOICE AS SOME GRID SIZES MAY VARY DUE TO MANUFACTURING/ SHIPPING RESTRAINTS.

IT IS CRITICAL FOR CONTRACTOR/FRANCHISEE TO VERIFY THE EXACT PLACEMENT OF ALL ELECTRICAL OUTLETS LOCATED WITHIN OR NEAR GRIDWALLS.

HOTWORX
 THE SERVICES OF THIS DOCUMENT ARE LIMITED TO THE PROJECT AND SITE SPECIFICALLY IDENTIFIED HEREIN. THE USER SHALL BE RESPONSIBLE FOR OBTAINING ALL NECESSARY PERMITS AND REGULATORY APPROVALS. THE USER SHALL BE RESPONSIBLE FOR OBTAINING ALL NECESSARY PERMITS AND REGULATORY APPROVALS. THE USER SHALL BE RESPONSIBLE FOR OBTAINING ALL NECESSARY PERMITS AND REGULATORY APPROVALS. THE USER SHALL BE RESPONSIBLE FOR OBTAINING ALL NECESSARY PERMITS AND REGULATORY APPROVALS.

| REVISION | |
|----------|------|
| DATE | REPL |
| | |
| | |
| | |

CONTACT
 Contact Development Team
 HOTWORX Franchisees
 development@hotworx.net

PROJECT
 Multiple Locations & Mobile Devices
 HOTWORX 5110 - INDC022
 424 S. Snelling Ave. N
 St. Paul, MN 55104
 02-78-2024

HOTWORX

SCALE
 NOT TO SCALE
 DATE
 02/28/2024
 DRAWN BY
 DEBBIE T.
 DRAWING
 TITLE

INTERIOR
 LOBBY
 ELEVATIONS

SHEET NO.
 6 OF 8

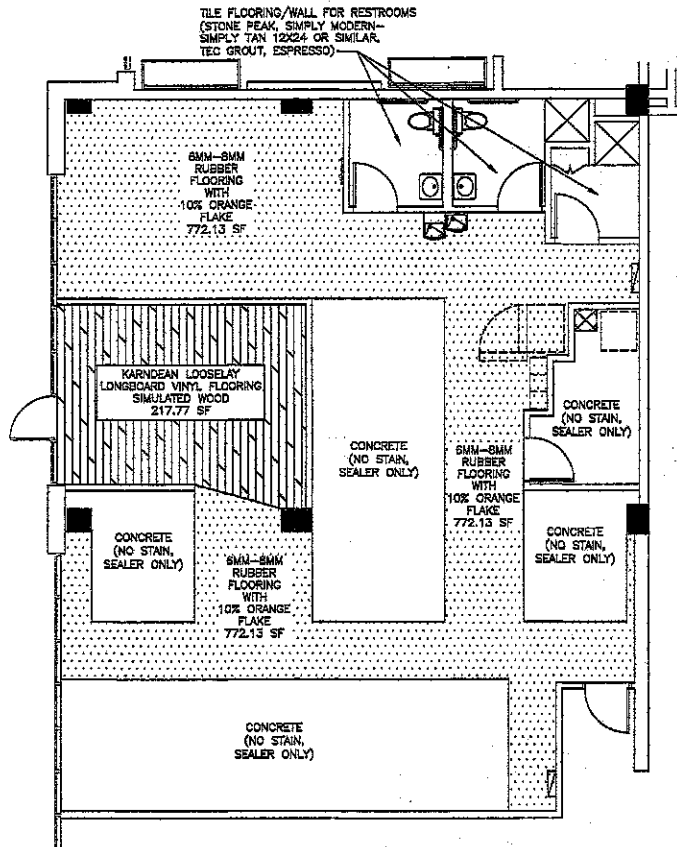

PROPOSED FLOORING PLAN
SCALE 1/4"=1'-0"

****NOTE:**
APPROXIMATE FOOTAGE OF FLOORING:
* VINYL SIMULATED WOOD: 217.77 S.F.
* RUBBER FLOORING: 772.13 S.F.

****NOTE-- ALL CONCRETE MUST BE LEVELED, PREPPED, AND SEALED BY CONTRACTOR BEFORE INTERIOR BRANDING COMPONENTS VENDOR CREW DOES THE INSTALL**

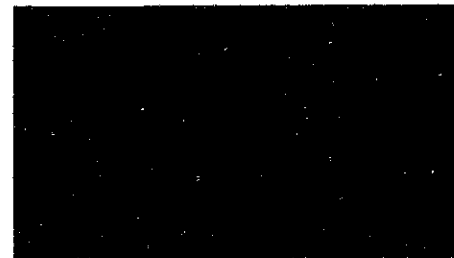

6MM-8MM RUBBER FLOORING WITH 10% ORANGE FLAKE
** PROVIDED AND INSTALLED BY INTERIOR BRANDING COMPONENTS VENDOR

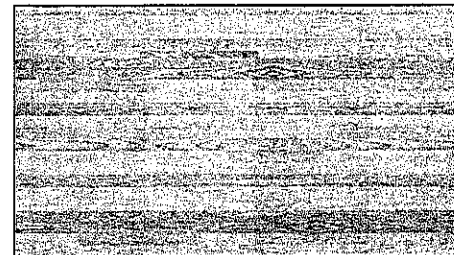

KARNDUAN LOOSELAY LONGBOARD VINYL FLOORING- SIMULATED WOOD
**PROVIDED AND INSTALLED BY INTERIOR BRANDING COMPONENTS VENDOR

NOTWORK

ALL WORK SHALL BE DONE IN ACCORDANCE WITH THE LATEST EDITIONS OF THE INTERNATIONAL BUILDING CODES AND ALL APPLICABLE LOCAL ORDINANCES. ALL WORK SHALL BE DONE IN ACCORDANCE WITH THE LATEST EDITIONS OF THE INTERNATIONAL BUILDING CODES AND ALL APPLICABLE LOCAL ORDINANCES. ALL WORK SHALL BE DONE IN ACCORDANCE WITH THE LATEST EDITIONS OF THE INTERNATIONAL BUILDING CODES AND ALL APPLICABLE LOCAL ORDINANCES.

REVISION

| DATE | INCL |
|------|------|
| | |
| | |
| | |

CONTACTS

Contact Development Team
NOTWORK Transitions
development@notwork.net

PROJECT

11/21/2024
423 S. Main Ave. N
55104
02-28-2024

NOTWORK.

SCALE
1/4" = 1'-0"
DATE
02/28/2024
DRAWN BY
JESSE T.
DRAWING TITLE

PROPOSED FLOORING PLAN

SHEET NO.
7 OF 8

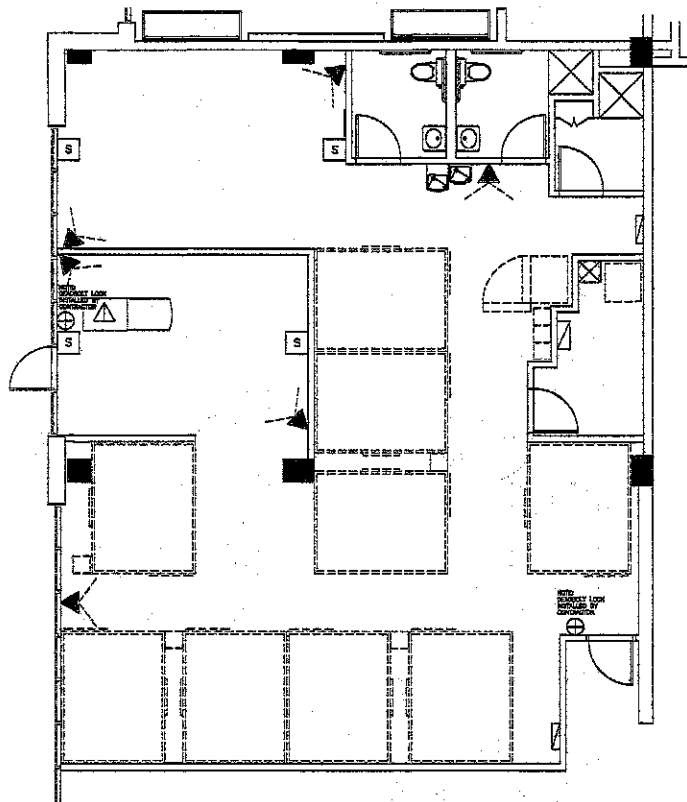

PROPOSED SECURITY/SOUND EQUIPMENT PLAN
SCALE 1/4"=1'-0"

SECURITY LEGEND

- ☒ HEAD END EQUIPMENT (1)
 - 4"x4" PLYWOOD BACKBOARD
 - ELECTRICAL OUTLET BY BACKBOARD
 - ISP ROUTER LOCATION
 - ALL CONDUIT STUBBED ABOVE BACKBOARD FROM CAMERA LOCATIONS & ACCESS CONTROL DOOR.
 - ⊕ ACCESS CONTROL DOOR (2) - 3/4" CONDUIT FROM BACKBOARD TO STUBBED INTO TOP OF DOORFRAME
 - ▲ CAMERA LOCATIONS (6) - SINGLE GANG BOXES 10' AFF WITH MIN 1/2" CONDUIT PER RUN STUBBED @ ABOVE BACKBOARD. 4 LOCATIONS TO BACKBOARD
 - ▽ ISP INSTALLED IN SERVICE STAND WILL NEED (1) - 3/4" MIN CONDUIT FROM INSIDE SERVICE STAND TO BACKBOARD. NOTE: THIS LOCATION IS NEEDED DUE TO LENGTH OF THE BUILDING FOR GOOD WIFI COVERAGE IN THE FRONT
- Note:
Head End Equipment (1)
-4"x4" Plywood Backboard
-Electrical Outlet By Backboard
-ISP Router Location
-All Home Run EMT Conduit Stubbed Above Backboard From Camera Locations, Service Stand & Access Control Door.
- Access Control Door (2) Home Run 3/4" EMT Conduit From Backboard To Single Gang Box Mounted At The Top Of Doorframe Mullion.
- Camera Locations (6) Single Gang Boxes 10' AFF With Min 1/2" Home Run EMT Conduit Per Run Stubbed Above Backboard. Cameras have an approximate angle of view of 108 degrees. For more information contact security vendor.
- Service Stand (1) Home Run 3/4" EMT Conduit From Backboard To Service Stand For Hardwired Data Lines For POS & Phone.

SECURITY LEGEND

- ⊞ ROCKBOT SPEAKERS (4) PER LOCATION

**NOTE:
*SECURITY AND SOUND REQUIREMENTS ARE 250 MBPS

*AMP/CONTROLLER TO BE INSTALLED IN A SECURE LOCATION WITHOUT PUBLIC ACCESS. (TYPICALLY INSTALLED ADJACENT TO THE SECURITY BACKBOARD) FRANCHISEE TO VERIFY EXACT LOCATION

POSTWORK
ALL WORK SHALL BE DONE IN ACCORDANCE WITH THE CITY OF HOUSTON'S ELECTRICAL CODE AND ALL APPLICABLE REGULATIONS. ALL WORK SHALL BE DONE IN ACCORDANCE WITH THE CITY OF HOUSTON'S ELECTRICAL CODE AND ALL APPLICABLE REGULATIONS. ALL ELECTRICAL & PLUMBING WORK TO BE BY LICENSED ELECTRICIAN & PLUMBER. ALL MATERIALS & EQUIPMENT TO BE USED SHALL BE APPROVED BY THE CITY OF HOUSTON. ALL MATERIALS & EQUIPMENT TO BE USED SHALL BE APPROVED BY THE CITY OF HOUSTON.

REVISION

| DATE | INT'L |
|------|-------|
| | |
| | |
| | |

CONTACTS
Contact Development Team
HJWORK Franchising
development@hjwork.net

PROJECT
Natalia Givens & Alek Dvornik
HJWORK STENO - INCO092
5477 West Loop South, Suite 104
Houston, TX 77056
02-23-2024

HJWORK

SCALE
1/4" = 1'-0"
DATE
07/25/2024
DRAWN BY
DEBBIE T.
DRAWING
TITLE

PROPOSED
SECURITY/SOUND
PLAN

SHEET NO.
8 OF 8



HOTWORX

