

RLH SAO 18-51



# APPLICATION FOR APPEAL

Saint Paul City Council – Legislative Hearings

RECEIVED

310 City Hall, 15 W. Kellogg Blvd.

Saint Paul, Minnesota 55102

JUL 26 2018

Telephone: (651) 266-8585

CITY CLERK

**We need the following to process your appeal:**

- \$25 filing fee (non-refundable) (payable to the City of Saint Paul) (if cash: receipt number 820538)
- Copy of the City-issued orders/letter being appealed
- Attachments you may wish to include 3
- This appeal form completed
- Walk-In OR  Mail-In
- for abatement orders only:  Email OR  Fax

<b>HEARING DATE &amp; TIME</b> (provided by Legislative Hearing Office) Tuesday, <u>Aug. 7, 2018</u>
Time <u>11:00</u>
Location of Hearing: <u>Room 330 City Hall/Courthouse</u>

\*LEFT MESSAGE WITH SEAN @ 4:09 P.M ON 7-26-18 SAYING WE TOOK THE APPEAL

## Address Being Appealed:

Number & Street: 652 HALL AVE City: St. Paul State: MN Zip: 55107

Appellant/Applicant: Michael Schultz Email \_\_\_\_\_

Phone Numbers: Business \_\_\_\_\_ Residence \_\_\_\_\_ Cell \_\_\_\_\_  
Alternate contact phone: Lily Schultz 651-292-1704

Signature: [Handwritten Signature] Date: 7-26-2018

Name of Owner (if other than Appellant): \_\_\_\_\_

Mailing Address if Not Appellant's: \_\_\_\_\_

Phone Numbers: Business \_\_\_\_\_ Residence \_\_\_\_\_ Cell \_\_\_\_\_

## What Is Being Appealed and Why? *Attachments Are Acceptable*

- Vacate Order/Condemnation/Revocation of Fire C of O
- Summary/Vehicle Abatement Shed structure
- Fire C of O Deficiency List/Correction
- Code Enforcement Correction Notice
- Vacant Building Registration
- Other (Fence Variance, Code Compliance, etc.)



CITY OF SAINT PAUL  
CODE ENFORCEMENT  
375 Jackson Street, Suite 220  
Saint Paul, MN 55101- 1806

### SUMMARY ABATEMENT ORDER

MICHAEL L SCHULTZ  
652 HALL AVE  
ST PAUL MN 55107- 2839

*Yog hais tias koj hais tsis to taub tsab ntawv no, hu rau tus txhais lus ntawm (651) 266- 8989. Nws yog pab dawb zwb. Si necessita un traductor, por favor llamanos al (651)266- 8989. No costo.*

As owner or person(s) responsible for 652 HALL AVE : please eliminate the nuisance conditions which are in violation of Chapter 45 of Saint Paul Legislative Code.

1. Remove improperly stored or accumulated refuse which may include: garbage, rubbish, loose and scattered litter, discarded furniture, appliances, vehicle parts, scrap wood and metal, recycling materials, household items, building materials or rubble, tires, brush, etc., from entire property including yard, boulevard, alley, and driveway.  
**PLEASE REMOVE THE UNAPPROVED TEMPORARY STRUCTURE FROM THE DRIVEWAY.**

*Paula Seely  
651-266-1916*

Comply before: July 20, 2018

Questions: Call your Inspector Sean Westenhofer

Phone Number: 651- 266- 1914

Thank you - we appreciate your cooperation!

*Photo may not show all areas which need to be abated*

If you do not correct the nuisance or file an appeal before July 20, 2018, the City will correct the nuisance and charge all cost, including boarding costs, against the property as a special assesment to be collected in the same way as property taxes. Charges: If the City corrects the nuisance, the charges will include the cost of correction, inspection, travel time, equipment, etc. The rate will be approximately \$260 per hour plus expenses for abatement.

**APPEALS:**You may appeal this order and obtain a hearing before the Legislative Hearing Officer by completing an appeal application before the deadline noted above or seven (7) days after the date mailed, whichever comes first. No appeals may be filed after that date. You may obtain an appeal application from the City Clerk's Office, Room 310 City Hall, 15 W. Kellogg Blvd., St. Paul, MN 55102. (651) 266- 8688. You must submit a copy of this Order with your appeal application.

**WARNING:** If violations are not corrected by the compliance date, the city's costs will be assessed to the property taxes of the related property. If additional new violations are discovered within the next 12 months, additional charge may apply.

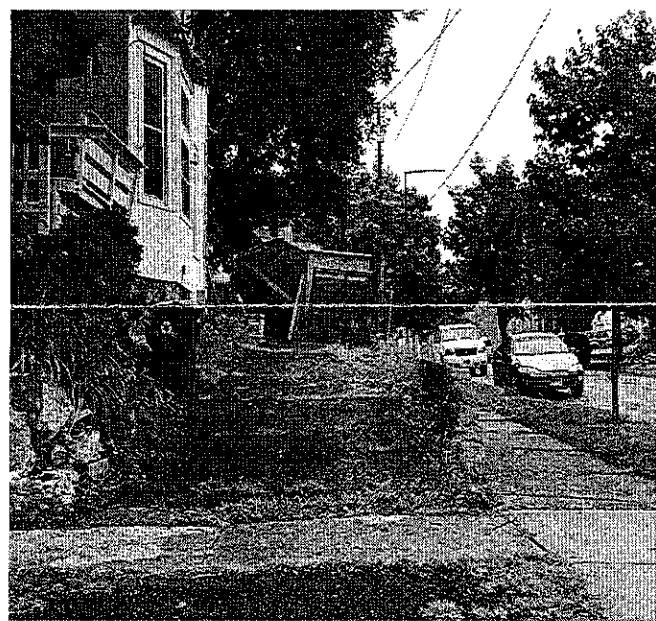

*9AM-7-18-18 - called & left message - No call back - called again but left no mess.  
8:30AM-7-19-18 called & left message - No call back called again but left no mess.  
2:30pm 7-19-18 called Appeals & she gave me # of Paula Seely - called & left message 1:20 again  
7:30 AM 7-20-18 Sean called back and said he would attend it for another week until next friday & To file an appeal on the shed.*

Also sent to:  
Occupant

ATTACHMENT #2

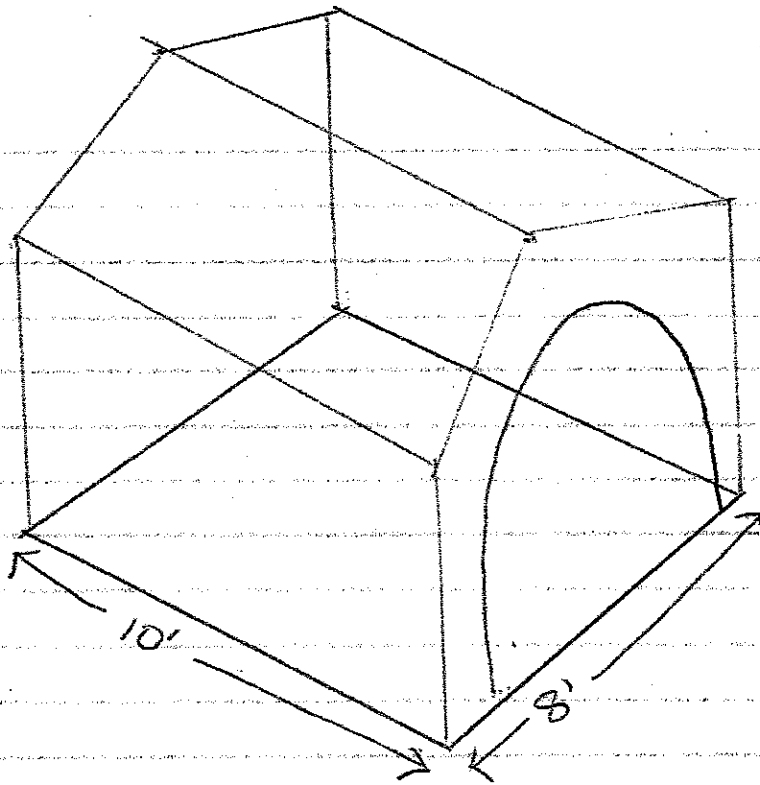

From: Menard

ALL 4 CORNERS  
Anchored by  
18' Screws into  
the ground

Covered by  
fiberglass tarp like  
material

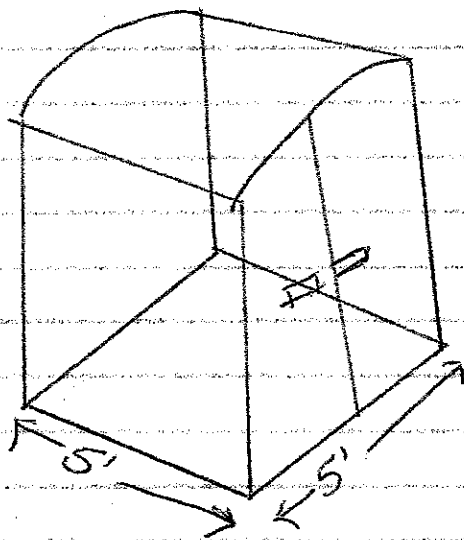

from: Menards

Rubbermaid  
Shed

tuff stuff  
Plastic w/floor

ATTACHMENT #  
3

I have No Garage  
used for storage of  
lawn tractor ~~and~~  
e snowblower & tools

# STAMP - Activity Detail

[New Search](#)

[Help using this report](#)

## 652 Hall Ave

Click [here](#) to access other applications using this address - GISmo, MapIT, and Ramsey County Info

<b>Run Date:</b> 07/23/18 08:28 AM	<b>In Date:</b> 07/05/18	<b>Status:</b> Under Review
<b>Folder</b> 18 080309	<b>Entered By:</b> Vue, Der	<b>Closed:</b>
<b>ID#:</b>		
<b>Type:</b> CS - CSO Complaint - Garbage Rubbish - Complaint		

**Description:**

Temporary structure in driveway.

**Comment:**

**07/05/2018** : Code Printed: 07/05/2018  
**07/13/2018** : New SA Photo Printed: 07/13/2018

**Document:**

[Single PDF: SA Letter Document](#) - Generated: 07/13/2018 - Sent: 07/13/2018  
[Batch PDF: Complaint Document](#) - Generated: 07/05/2018 - Sent: 07/05/2018

\* Note: Clicking on above document links may not reflect the exact formatting of the original document.

**People:**

Owner:  
Michael L Schultz  
652 Hall Ave  
St Paul MN 55107-2839  
651-307-7097

**Info Value:**

Behavior Complaint: No  
Possible Student Housing?: No  
Homeless Encampment?: No

Ward: 2  
District Council: 3  
See Click Fix: No

---

**DSI CS Complaint Admin**

**Assigned To:** CSO Complaint Analyst Pool 651-266-8989  
Next Schedule Date: 08/09/19

---

**DSI Code Enforcement Response**

**Assigned To:** Westenhofer, Sean 651-266-1914  
07/13/2018: \*Compliance Recheck - Found a temporary structure in the driveway  
Garbage/Rubbish (Summary Abatement)

---

**DSI Code Enforcement Reinspection**

**Next Schedule Date:** 07/27/18