



Larkin Hoffman

8300 Norman Center Drive
Suite 1000
Minneapolis, Minnesota 55437-1060

GENERAL: 952-835-3800
FAX: 952-896-3333
WEB: www.larkinhoffman.com

June 18, 2015

Environmental Quality Board
Attn: Courtney Ahlers-Nelson, Principal Planner
520 Lafayette Road
Saint Paul, MN 55155

VIA ELECTRONIC MAIL

Minnesota Pollution Control Agency
Attn: Dan Card
Environmental Review Program
520 Lafayette Road
Saint Paul, MN 55155

**Re: Hawkins Inc. EAW Petition (701 Barge Channel Road, St. Paul, Minnesota)
Notice of Final Decision by City by Operation of Statute**

Dear Ms. Ahlers-Nelson and Mr. Card:

This firm represents Hawkins Inc. ("Hawkins") with regard to the proposed storage tank replacement and upgrade project (the "Project") 701 Barge Channel Road in the City of St. Paul (the "City"). On June 9, 2015, a petition (the "Petition") for an Environmental Assessment Worksheet (EAW) was submitted to the Environmental Quality Board (EQB) by petitioners' representative Salina Amey. This letter is to inform you that on May 15, 2015, the Project was approved by the City by operation of statute under Minnesota Statutes Section 15.99; therefore, the Project is exempt from environmental review under Minnesota Rules 4410.4600, subp. 2(A) as all final governmental decisions have been made.

The project application for a conditional use permit (CUP) was deemed complete by the City of St. Paul on March 16, 2015, which means the 60-day limit expired on May 15, 2015. On April 24, 2015, the City Planning Commission voted unanimously to approve Hawkins's CUP. Hawkins subsequently commenced construction of the Project on April 27, 2015 under building permit 2015-027236 (*see attached* permitting record). On May 4, 2015, the Planning Commission's approval of the CUP was appealed by Salina Amey and Kathy Larson. Notwithstanding the appeal, the 60-day limit subsequently expired on May 15, 2015, and the City's failure to deny the application within the 60-day period results in automatic approval under section 15.99.

Please confirm in writing that the Petition will be returned to the petitioners' representative as the Project is exempt under Minnesota Rules.

Environmental Quality Board

June 18, 2015

Page 2

Please do not hesitate to contact me with any questions.

Sincerely,

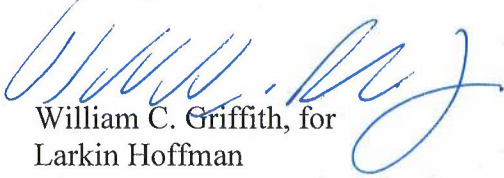

William C. Griffith, for
Larkin Hoffman

Direct Dial: 952-896-3290

Direct Fax: 952-842-1729

Email: wgriffith@larkinhoffman.com

Enclosures

cc:

Will Seuffert, EQB Executive Director
John Linc Stine, MPCA Commissioner
Shari Moore, City Clerk
Jerry Hendrickson, Deputy City Attorney
Mayor Christopher Coleman
Council President Stark and St. Paul City Councilmembers
Josh Williams, Senior City Planner
Rich Erstad, Hawkins Inc.
Robert C. Long, Larkin Hoffman

Griffith, William C.

From: Bergman, David (CI-StPaul) <david.bergman@ci.stpaul.mn.us>
Sent: Wednesday, April 22, 2015 9:58 AM
To: Drew Scott
Subject: RE: Hawkins, Inc. Terminal 2 Hazardous Materials Permit Application

Drew,

The permit number is: 2015 – 027236

I can fax or e-mail you a copy this p.m.

Dave Bergman
651-266-8944

From: Drew Scott [<mailto:drew.scott@HawkinsInc.com>]
Sent: Wednesday, April 22, 2015 9:08 AM
To: Bergman, David (CI-StPaul); Wiese, Angie (CI-StPaul)
Cc: Graham Mahal; Chris James (CJames@marcyconstruction.com); 'brad@bolander.com'
Subject: RE: Hawkins, Inc. Terminal 2 Hazardous Materials Permit Application

Dave,

Per conversation with Graham, I understand you have authorized us to proceed forward with this work. Can you or Angie please reply all with the Permit # for our records?

Thanks,

Drew Scott | Project Engineer | Hawkins, Inc.
2381 Rosegate | Roseville MN 55113
O. 612.331.6910 | D. 612.617.8595 | M. 209.712.3763
drew.scott@hawkinsinc.com | www.hawkinsinc.com

From: Graham Mahal
Sent: Wednesday, April 15, 2015 5:01 PM
To: Chris James (CJames@marcyconstruction.com); 'brad@bolander.com'
Cc: Drew Scott
Subject: FW: Hawkins, Inc. Terminal 2 Hazardous Materials Permit Application

For your records.

Regards-

Graham Mahal
Hawkins, Inc.

From: Graham Mahal
Sent: Wednesday, April 15, 2015 4:57 PM
To: 'david.bergman@ci.stpaul.mn.us'

Cc: 'Angie Wiese (angie.wiese@ci.stpaul.mn.us)'

Subject: Hawkins, Inc. Terminal 2 Hazardous Materials Permit Application

Mr. Bergman,

Please find attached the Hazardous Materials Permit Application completed per your instructions. Should have any question regarding the permit application, please feel me to contact me at your convenience. Please forward any technical questions you may have regarding the project details to either Drew Scott (Hawkins, Inc.).

Thank you for your assistance.

Regards-

Graham Mahal
Hawkins, Inc.
612.617.8556

This email has been scanned by the Symantec Email Security.cloud service.

For more information please visit <http://www.symanteccloud.com>

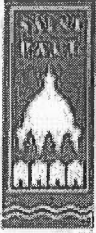

CITY OF SAINT PAUL
 Department of Safety and Inspections
 Fire Inspection Division
 375 Jackson Street, Suite 220
 Saint Paul, Minnesota 55101-1806
 Phone: 651-266-8989 Fax: 651-266-8951

**HAZARDOUS MATERIALS
 PERMIT APPLICATION**

Incomplete information will result in rejection of application. No work can begin prior to approval.

Date: 15-April-2015

Permit Number: _____

Project Address: <u>701 Barge Channel Road St. Paul, MN 55107</u>	Building Name: <u>Hawkins - Terminal 2</u>
--	---

Contractor Information

Name: Marcy Construction (Carl Bolander & Sons - Removal) **MPCA ID #:** 89

Address: 2246 Edgewood Avenue, St. Louis Park, MN 55426 **Phone:** (952) 525-7306

Contact Person: Chris James **Fax:** (952) 525-9754

Property Owner Name: Hawkins, Inc. ATTN: Drew Scott

Property Owner Address: 2381 Rosegate, Roseville, MN **Phone:** (612) 617-8595

Project: Install (X) Repair () Alter () Abandon () Remove (X)*
 * If removed, where will tank be taken for disposal? Alter Metal Recycling or Northern Metal Recycling

Tank Information

Number of Tanks: Remove - 1 Field
Install - 8 Shop Fabricated

Tank Type: Protected AST () Aboveground (X) Underground () Other _____

Tank Capacity: Remove - 1 X 440,000 Gallon
Install - 8 X 50,000 Gallon

Tank Specification/Listing: Remove - Insulated, Rubber Lined, Steel Tank
Install - Shop Fabricated FRP Tanks **Tank Contents:** Remove - Hydrofluosilicic Acid
Install - Hydrochloric Acid

For LPG & Compressed Gas Tanks: _____ **Tank Surface Area in Sq. Ft.** _____ **Total Relief Valve Capacity** _____

Estimated Start Date: <u>20 - April - 2015</u>	Estimated Finish Date: <u>30 - Sept - 2015</u>
---	---

**** Required Attachments ****

Initial Fee \$150.00 + \$50.00 per Tank **Site Plan (X) Mechanical Plan ()**
 (Make check payable to City of Saint Paul)

Applicant certifies that all information is correct and that all pertinent state regulations and city ordinances will be complied with in performing the work for which this permit is issued. Final approval subject to field inspection.

Applicant's Signature: *Colin W. Mahal* Date: 15-April-2015



Signature of Cardholder (required for all charges): *Colin W. Mahal*

American Express Discover MasterCard Visa

Expiration
Month/Year
▶▶

Enter Account
Number ▶

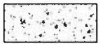
SYMBOL LEGEND

	REMOVE AND DISPOSE OR RECLAIM EXISTING BITUMINOUS PAVEMENT SECTION
	REMOVE AND DISPOSE OF EXISTING CONCRETE PAVEMENT SECTION
	REMOVE AND SALVAGE EXISTING GRAVEL

KEY NOTES



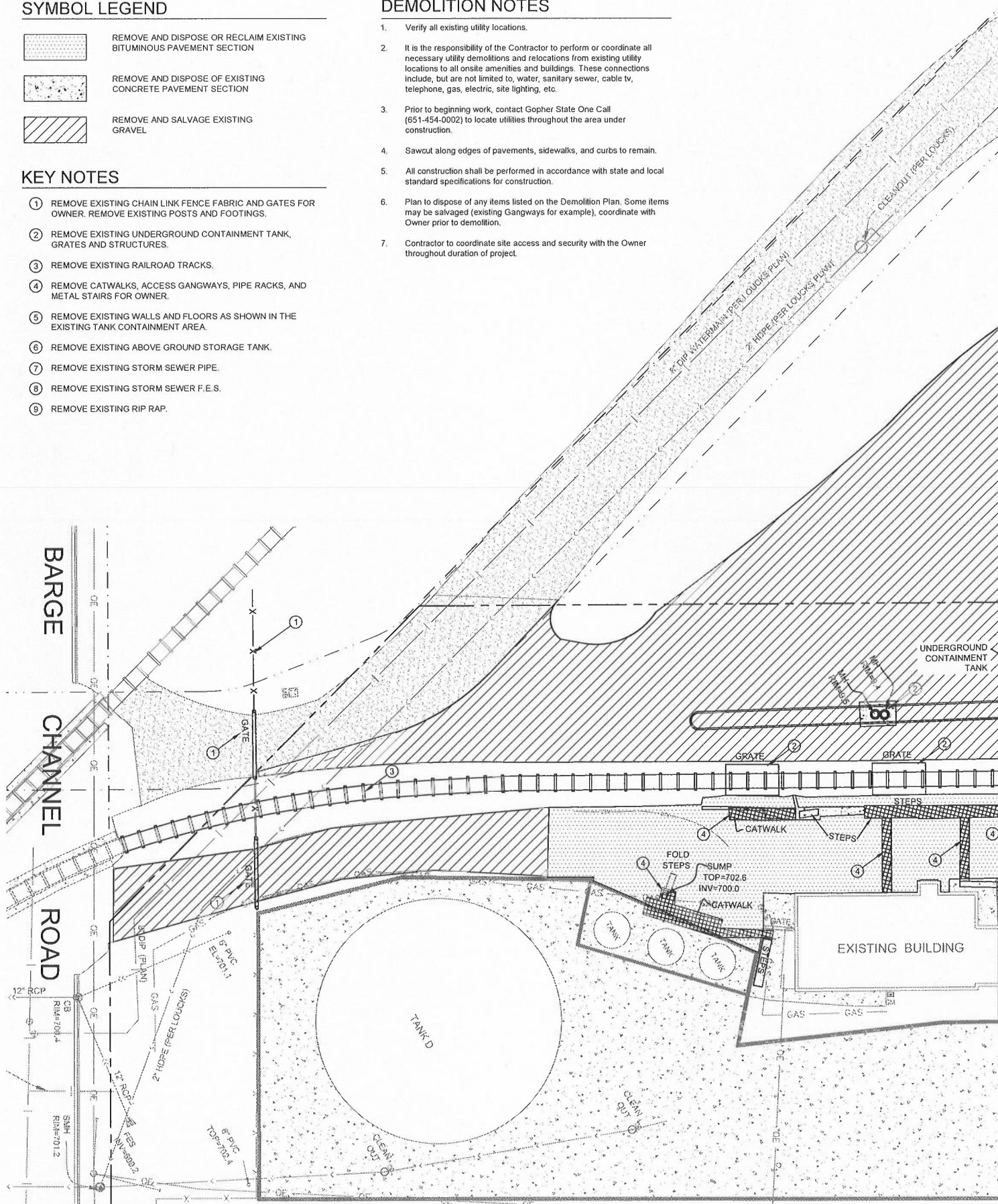

- ① REMOVE EXISTING CHAIN LINK FENCE FABRIC AND GATES FOR OWNER. REMOVE EXISTING POSTS AND FOOTINGS.
- ② REMOVE EXISTING UNDERGROUND CONTAINMENT TANK, GRATES AND STRUCTURES.
- ③ REMOVE EXISTING RAILROAD TRACKS.
- ④ REMOVE CATWALKS, ACCESS GANGWAYS, PIPE RACKS, AND METAL STAIRS FOR OWNER.
- ⑤ REMOVE EXISTING WALLS AND FLOORS AS SHOWN IN THE EXISTING TANK CONTAINMENT AREA.
- ⑥ REMOVE EXISTING ABOVE GROUND STORAGE TANK.
- ⑦ REMOVE EXISTING STORM SEWER PIPE.
- ⑧ REMOVE EXISTING STORM SEWER F.E.S.
- ⑨ REMOVE EXISTING RIP RAP.

DEMOLITION NOTES

1. Verify all existing utility locations.
2. It is the responsibility of the Contractor to perform or coordinate all necessary utility demotions and relocations from existing utility locations to all onsite amenities and buildings. These connections include, but are not limited to, water, sanitary sewer, cable tv, telephone, gas, electric, site lighting, etc.
3. Prior to beginning work, contact Gopher State One Call (651-454-0002) to locate utilities throughout the area under construction.
4. Sawcut along edges of pavements, sidewalks, and curbs to remain.
5. All construction shall be performed in accordance with state and local standard specifications for construction.
6. Plan to dispose of any items listed on the Demolition Plan. Some items may be salvaged (existing Gangways for example), coordinate with Owner prior to demolition.
7. Contractor to coordinate site access and security with the Owner throughout duration of project.



SYMBOL LEGEND

	NEW 6" BITUMINOUS PAVEMENT OVER NEW 8" CRUSHED AGGREGATE BASE. FINAL LIFT AT END OF CONSTRUCTION. SEE DETAIL 1/C5
	NEW 3" BITUMINOUS PAVEMENT OVER NEW 8" CRUSHED AGGREGATE BASE. SEE DETAIL 2/C5
	NEW 8" CONCRETE PAVEMENT OVER NEW 6" CRUSHED AGGREGATE BASE. SEE DETAIL 3/C5
	NEW 12" AGGREGATE SECTION FOR RAIL SUB-BALLAST
	WASHED AGGREGATE SECTION

WHERE APPLICABLE, DIMENSIONS ARE FROM BACK OF CURB TO BACK OF CURB OR BACK OF CURB TO END OF STALL LINE.

NOTE: OBTAIN CLASS V AGGREGATE MATERIAL FROM HAWKINS' ROSEMOUNT FACILITY. COORDINATE W/ OWNER'S REPRESENTATIVE.

NOTES

- Where applicable, dimensions are from back of curb to back of curb or back of curb to end of stall line.
- Contractor shall obtain Class V Aggregate Material from Hawkins' Rosemount Facility. Coordinate with Owner's representative.
- See Structural Plans for details associated with Rail, Truck, and Tank Containment areas.
- See rail specific details, coordinate Sub-ballast elevations with Rail Contractor. Rail Contractor to provide rail crossing.

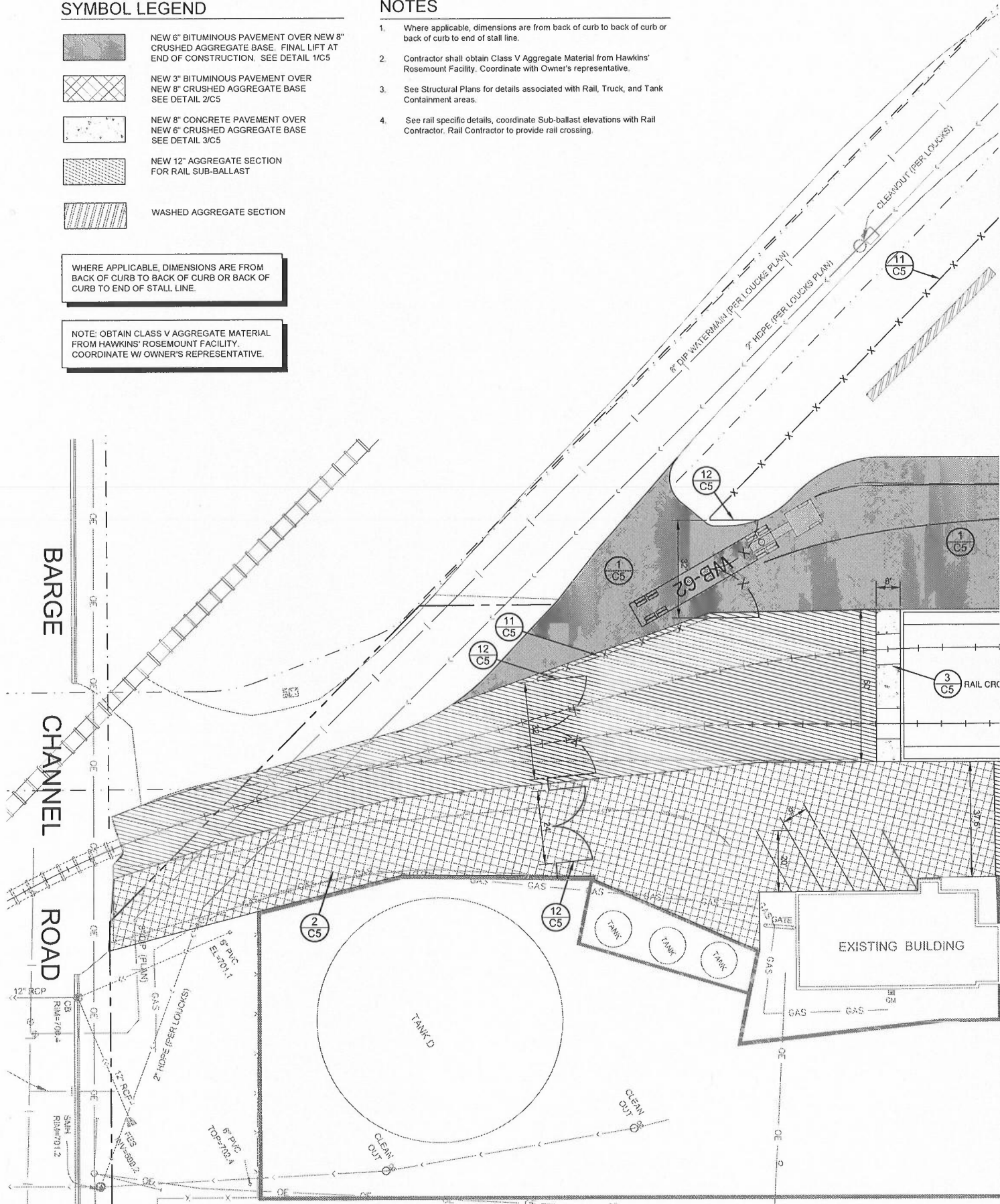

GRADING NOTES

- All elevations with an asterisk (*) shall be field verified. If elevations vary significantly, notify the Engineer for further instructions.
- Grades shown in paved areas represent finish elevation.
- Restore all disturbed areas with 4" of good quality topsoil and seed.
- All construction shall be performed in accordance with state and local standard specifications for construction.

EROSION CONTROL NOTES

- See Sheet C6 for Erosion Control Notes.

LEGEND

	950	EXISTING CONTOURS
	950	PROPOSED CONTOURS - MAJOR INTERVAL
	949	PROPOSED CONTOURS - MINOR INTERVAL
		GRADE BREAK LINE
	2.0%	GRADE SLOPE
		SILT FENCE
		RIP-RAP / ROCK CONST. ENTRANCE
		INLET PROTECTION
		CONCRETE WASHOUT STATION
	950.00 TC 949.50 GL	
SPOT ABBREVIATIONS:		
	TC - TOP OF CURB	
	GL - GUTTER LINE	
	A - AGGREGATE	
	B - BITUMUNOUS	
	C - CONCRETE	
	EO - EMERGENCY OVERFLOW	
	TW - TOP OF WALL	
	BW - BOTTOM OF WALL (F/G)	
	(HP) - HIGH POINT	
	(*) - EXISTING TO BE VERIFIED	

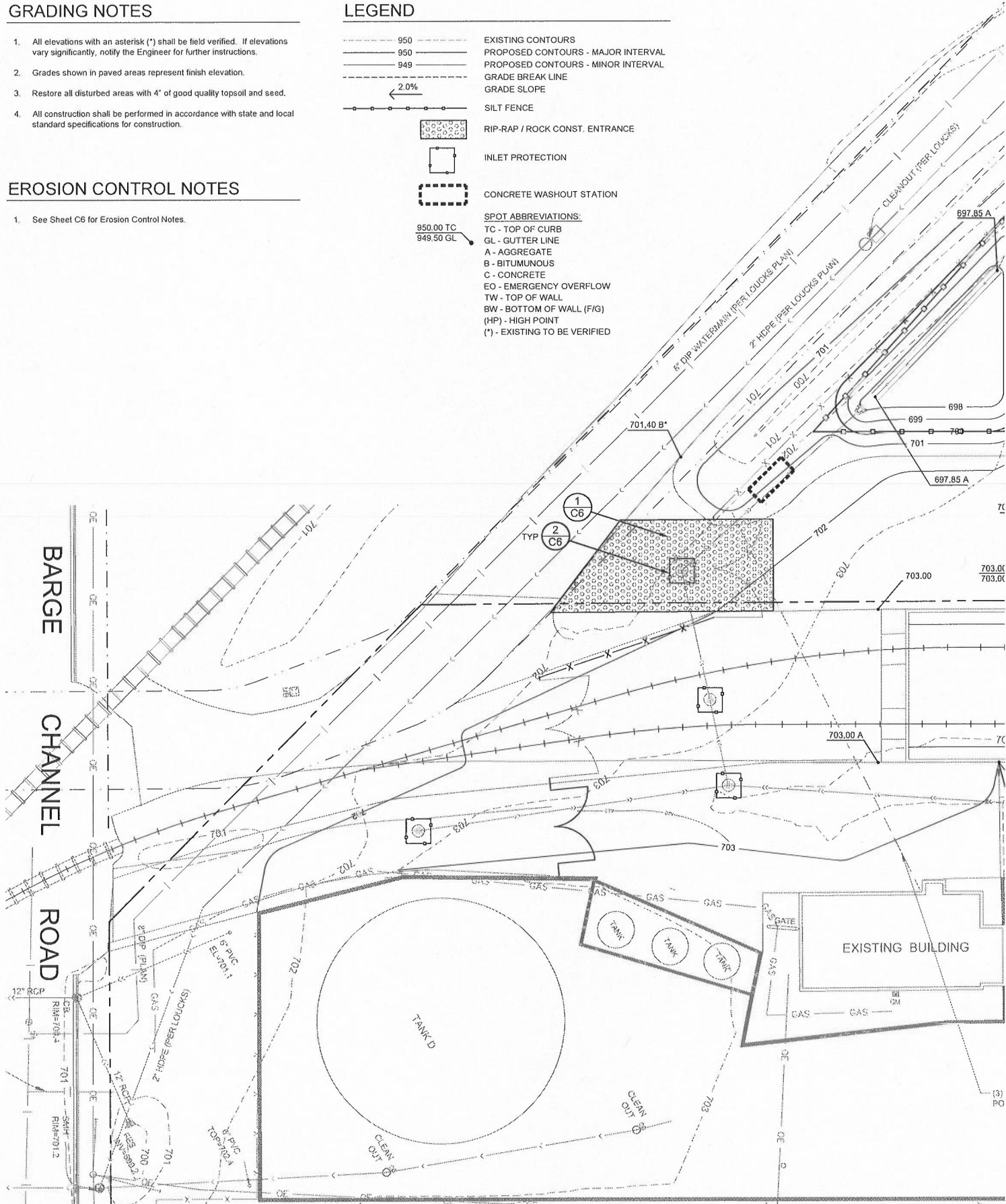

UTILITY NOTES

1. It is the responsibility of the contractor to perform or coordinate all necessary utility connections and relocations from existing utility locations to the proposed building, as well as to all onsite amenities.
2. All service connections shall be performed in accordance with state and local standard specifications for construction. Utility connections (sanitary sewer, watermain, and storm sewer) may require a permit from the City.
3. The contractor shall verify the elevations at proposed connections to existing utilities prior to any demolition or excavation.
4. The contractor shall notify all appropriate engineering departments and utility companies 72 hours prior to construction. All necessary precautions shall be made to avoid damage to existing utilities.
5. Storm sewer requires testing in accordance with Minnesota plumbing code 4715.2820 where located within 10 feet of waterlines or the building.
6. HDPE storm sewer piping and fittings must meet materials and installation standards per Minnesota plumbing code 4715.0420 6C(4) and 4715.0540 C including ASTM D3212 joint pressure test and ASTM C2321 installation practices. The City requires RCP pipe within the public right-of-way.
7. All RCP pipe shown on the plans shall be MN/DOT class 3.
8. Maintain a minimum of 7' of cover over all water lines and sanitary sewer lines. Install water lines 18" above sanitary sewers, where the sanitary sewer crosses over the water line, install sewer piping of materials equal to watermain standards for 9 feet on both sides and maintain 18" of separation.
9. Where 7' of cover is not provided over sanitary sewer and water lines, install 2" rigid polystyrene insulation (MN/DOT 3760) with a thermal resistance of at least 5 and a compressive strength of at least 25 psi. Insulation shall be 4" wide, centered over pipe with 6" sand cushion between pipe and insulation. Where depth is less than 5', use 4" of insulation.
10. All watermain piping shall be class 52 ductile iron pipe unless noted otherwise.
11. See Project Specifications for bedding requirements.
12. Pressure test and disinfect all new watermains in accordance with state and local requirements.
13. Sanitary sewer piping shall be PVC, SDR-35 for depths less than 12', PVC SDR-26 for depths between 12' and 26', and class 52 D.I.P. for depths of 26' or more.
14. All new manholes, catch basins, and catch basin / manhole structures shall be constructed utilizing an external chimney seal that is capable of providing a sound seal from casting to pre-cast section. Chimney seals shall be Infi-shield Uni-band or an approved equal.

LEGEND

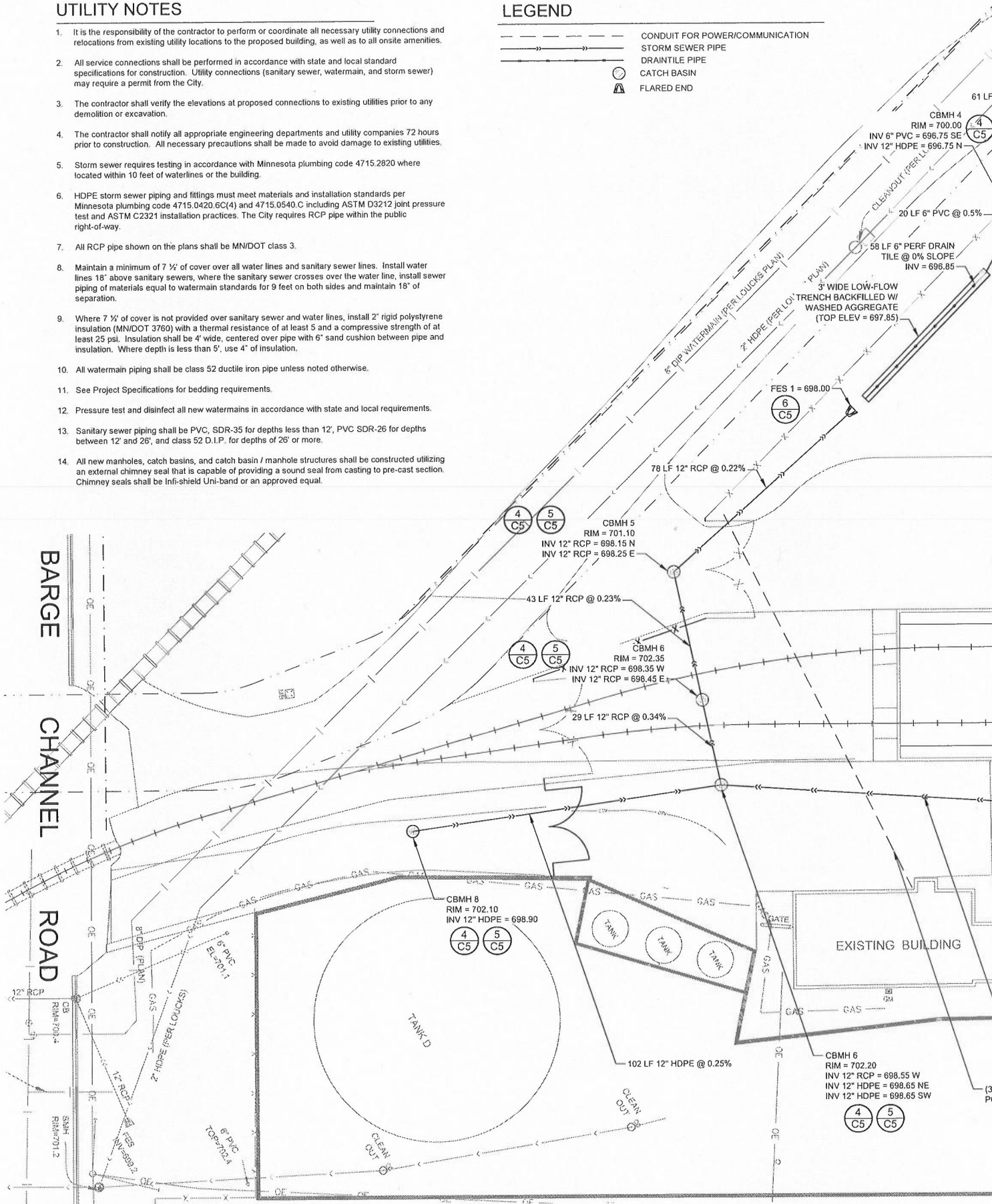
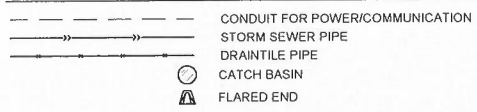

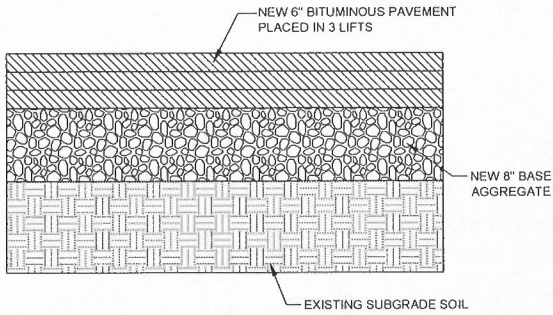

HEAVY-DUTY BITUMINOUS PAVEMENT SECTION

1
C5
NOT TO SCALE

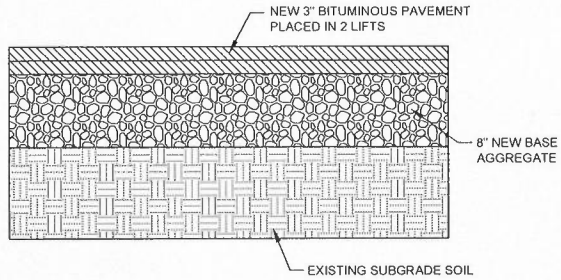

LIGHT-DUTY BITUMINOUS CONSTRUCTION DETAIL

2
C5
NOT TO SCALE

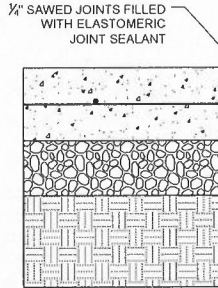

CC CONSTR

3
C5

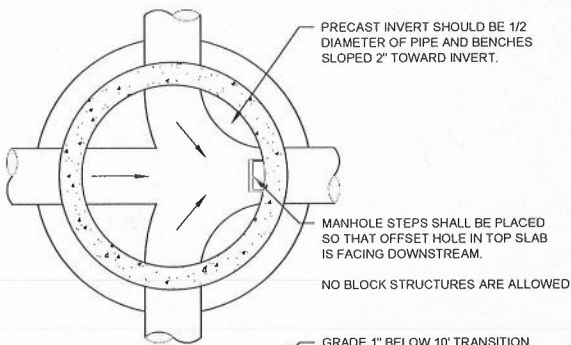

PLAN

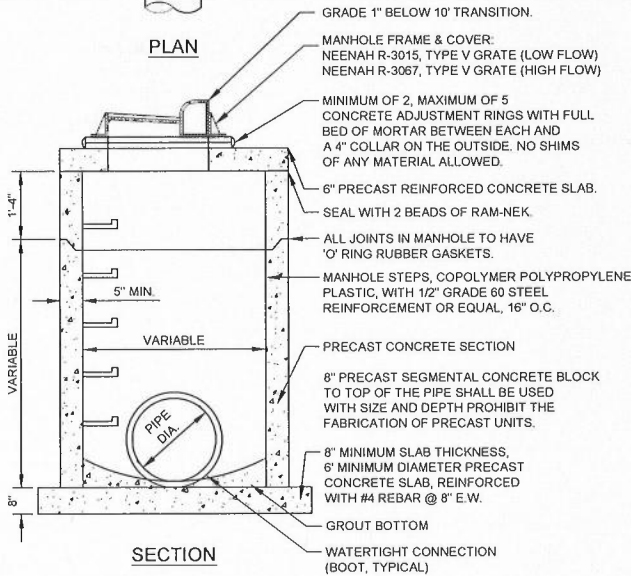

SECTION

CATCH BASIN MANHOLE DETAIL

4
C5
NOT TO SCALE

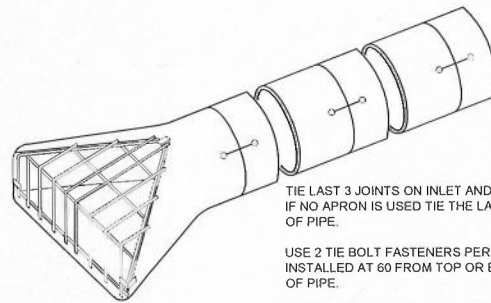

TIE LAST 3 JOINTS ON INLET AND OUTLET. IF NO APRON IS USED TIE THE LAST 3 SECTIONS OF PIPE.

USE 2 TIE BOLT FASTENERS PER JOINT INSTALLED AT 60 FROM TOP OR BOTTOM OF PIPE.

USE 5/8" TIE FOR PIPE SIZES 12" TO 27".
USE 3/4" TIE FOR PIPE SIZES 30" TO 66".
USE 1" TIE FOR PIPE SIZES OVER 72".

NUTS AND WASHERS ARE NOT REQUIRED ON PIPE SIZE LESS THAN 21".

TRASH GUARDS WILL BE REQUIRED ON 18" OR LARGER PIPE.

SIZE OF PIPE	BARS	BOLTS	"O"
12" TO 18"	3/4"	5/8"	4"
21" TO 42"	1"	3/4"	6"
48" TO 72"	1-1/4"	1"	12"

DRILL 8" INTO EXISTING CONCRETE AND INSERT NEW 1" DIA. SMOOTH EPOXY COATED STEEL DOWELS, 16" LONG AT 12" O.C.

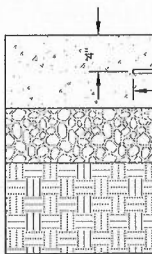

DOWEL

8
C5

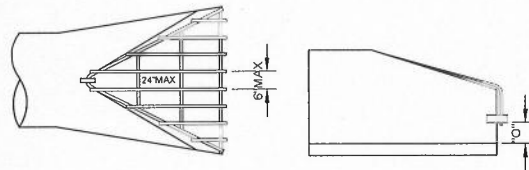

PROVIDE 3 CLIPS TO FASTEN TRASH GUARD TO F.E.S. HOT DIP GALVANIZE AFTER FABRICATION.

FLARED END SECTION DETAIL

6
C5
NOT TO SCALE

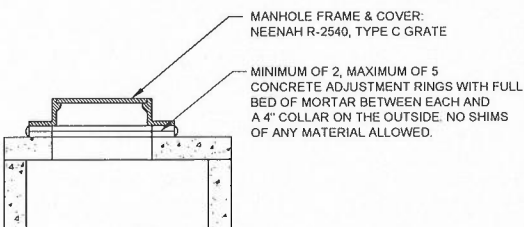
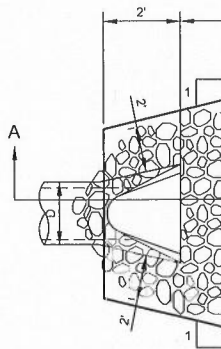

CATCH BASIN / MANHOLE FRAME DETAIL

5
C5
NOT TO SCALE

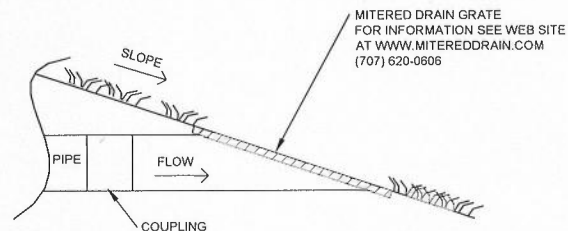

MITERED END GRATE DETAIL

7
C5
NOT TO SCALE

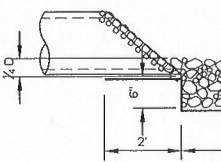

NOTE: 500X MIRAFI FABRIC OR EQUIV

9
C5
RIP-F

EROSION CONTROL NOTES

- Owner and Contractor shall obtain MPCA-NPDES permit. Contractor shall be responsible for all fees pertaining to this permit. The SWPPP shall be kept onsite at all times.
- Install temporary erosion control measures (inlet protection, silt fence, and rock construction entrances) prior to beginning any excavation or demolition work at the site.
- Erosion control measures shown on the erosion control plan are the absolute minimum. The contractor shall install temporary earth dikes, sediment traps or basins, additional siltation fencing, and/or disk the soil parallel to the contours as deemed necessary to further control erosion. All changes shall be recorded in the SWPPP.
- All construction site entrances shall be surfaced with crushed rock across the entire width of the entrance and from the entrance to a point 50' into the construction zone.
- The toe of the silt fence shall be trenched in a minimum of 6". The trench backfill shall be compacted with a vibratory plate compactor.
- All grading operations shall be conducted in a manner to minimize the potential for site erosion. Sediment control practices must be established on all down gradient perimeters before any up gradient land disturbing activities begin.
- All exposed soil areas must be stabilized as soon as possible to limit soil erosion but in no case later than 14 days after the construction activity in that portion of the site has temporarily or permanently ceased. Temporary stockpiles without significant silt, clay or organic components (e.g., clean aggregate stockpiles, demolition concrete stockpiles, sand stockpiles) and the constructed base components of roads, parking lots and similar surfaces are exempt from this requirement.
- The normal wetted perimeter of any temporary or permanent drainage ditch or swale that drains water from any portion of the construction site, or diverts water around the site, must be stabilized within 200 lineal feet from the property edge, or from the point of discharge into any surface water. Stabilization of the last 200 lineal feet must be completed within 24 hours after connecting to a surface water. Stabilization of the remaining portions of any temporary or permanent ditches or swales must be complete within 14 days after connecting to a surface water and construction in that portion of the ditch has temporarily or permanently ceased.
- Pipe outlets must be provided with energy dissipation within 24 hours of connection to surface water.
- All riprap shall be installed with a filter material or soil separation fabric and comply with the Minnesota Department of Transportation Standard Specifications.
- All storm sewers discharging into wetlands or water bodies shall outlet at or below the normal water level of the respective wetland or water body at an elevation where the downstream slope is 1 percent or flatter. The normal water level shall be the invert elevation of the outlet of the wetland or water body.
- All storm sewer catch basins not needed for site drainage during construction shall be covered to prevent runoff from entering the storm sewer system. Catch basins necessary for site drainage during construction shall be provided with inlet protection.
- In areas where concentrated flows occur (such as swales and areas in front of storm catch basins and intakes) the erosion control facilities shall be backed by stabilization structure to protect those facilities from the concentrated flows.
- Inspect the construction site once every seven days during active construction and within 24 hours after a rainfall event greater than 0.5 inches in 24 hours. All inspections shall be recorded in the SWPPP.
- All silt fences must be repaired, replaced, or supplemented when they become nonfunctional or the sediment reaches 1/3 of the height of the fence. These repairs must be made within 24 hours of discovery, or as soon as field conditions allow access. All repairs shall be recorded in the SWPPP.
- If sediment escapes the construction site, off-site accumulations of sediment must be removed in a manner and at a frequency sufficient to minimize off-site impacts.
- All soils tracked onto pavement shall be removed daily.
- All infiltration areas must be inspected to ensure that no sediment from ongoing construction activity is reaching the infiltration area and these areas are protected from compaction due to construction equipment driving across the infiltration area.
- Temporary soil stockpiles must have silt fence or other effective sediment controls, and cannot be placed in surface waters, including stormwater conveyances such as curb and gutter systems, or conduits and ditches unless there is a bypass in place for the stormwater.
- Collected sediment, asphalt and concrete millings, floating debris, paper, plastic, fabric, construction and demolition debris and other wastes must be disposed of properly and must comply with MPCA disposal requirements.
- Oil, gasoline, paint and any hazardous substances must be properly stored, including secondary containment, to prevent spills, leaks or other discharge. Restricted access to storage areas must be provided to prevent vandalism. Storage and disposal of hazardous waste must be in compliance with MPCA regulations.
- External washing of trucks and other construction vehicles must be limited to a defined area of the site. Runoff must be contained and waste properly disposed of. No engine degreasing is allowed onsite.
- All liquid and solid wastes generated by concrete washout operations must be contained in a leak-proof containment facility or impermeable liner. A compacted clay liner that does not allow washout liquids to enter ground water is considered an impermeable liner. The liquid and solid wastes must not contact the ground, and there must not be runoff from the concrete washout operations or areas. Liquid and solid wastes must be disposed of properly and in compliance with MPCA regulations. A sign must be installed adjacent to each washout facility to inform concrete equipment operators to utilize the proper facilities.
- Upon completion of the project and stabilization of all graded areas, all temporary erosion control facilities (silt fences, hay bales, etc.) shall be removed from the site.
- All permanent sedimentation basins must be restored to their design condition immediately following stabilization of the site.
- Contractor shall submit Notice of Termination for MPCA-NPDES permit within 30 days after Final Stabilization.

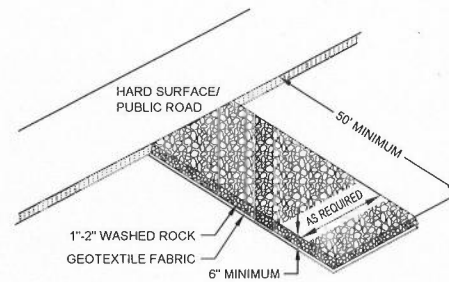

1
C6
ROCK CONSTRUCTION ENTRANCE
NOT TO SCALE

NOTE: FOR EXISTING CATCH BASINS IN PAVEMENT AREAS, SAND BAGS, AGGREGATE WRAPPED IN FILTER FABRIC, OR SEDIMENT TRAPS SHOULD BE USED.

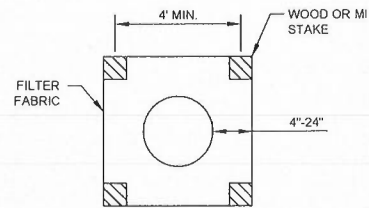

MAXIMUM DISTANCE BETWEEN POSTS IS 2'. BOTTOM OF FENCE IS BURIED IN TRENCH, SIMILAR TO NORMAL SILT FENCE INSTALLATION.

2
C6
SILT FENCE INLET SEDIMENT FILTER
NOT TO SCALE

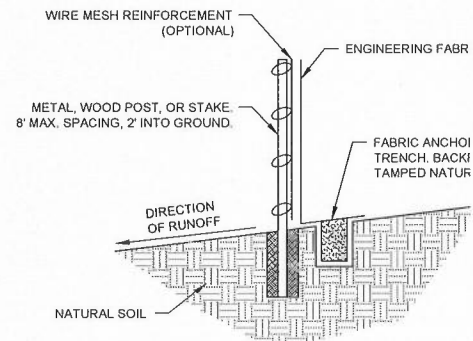

NOTE: DEPENDING UPON CONFIGURATION, ATTACH FABRIC TO V WITH HOG RINGS, STEEL POSTS WITH WIRES, OR WOOD POSTS WITH WIRE.

3
C6
SILT FENCE INSTALLATION DETAIL
NOT TO SCALE

210'-8" AT NORTH SIDE ONLY

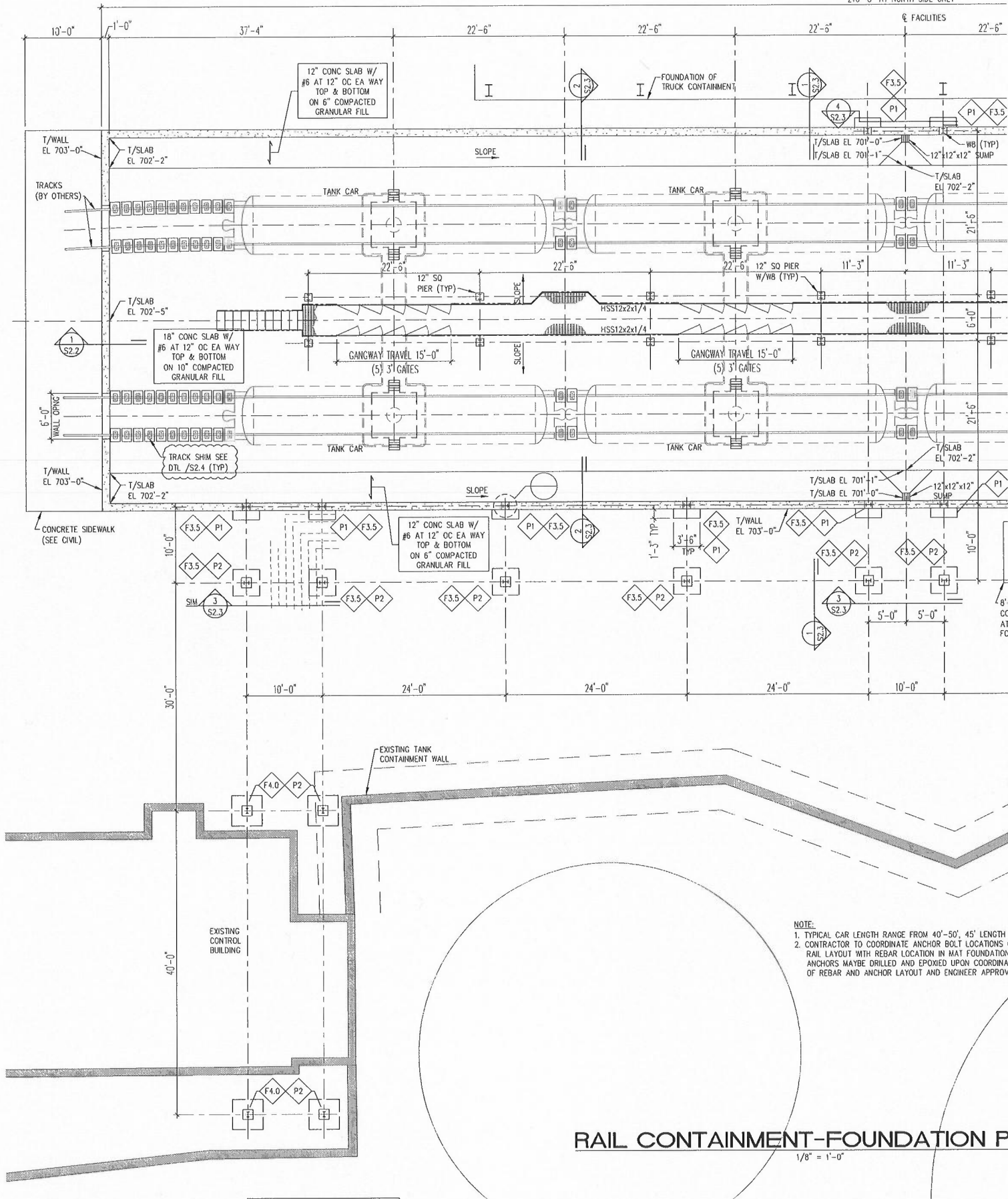

NOTE:
 1. TYPICAL CAR LENGTH RANGE FROM 40'-50', 45' LENGTH
 2. CONTRACTOR TO COORDINATE ANCHOR BOLT LOCATIONS (RAIL LAYOUT WITH REBAR LOCATION IN MAT FOUNDATION ANCHORS MAYBE DRILLED AND EPOXIED UPON COORDINA OF REBAR AND ANCHOR LAYOUT AND ENGINEER APPROV

RAIL CONTAINMENT-FOUNDATION P

1/8" = 1'-0"

210'-8" AT NORTH SIDE ONLY

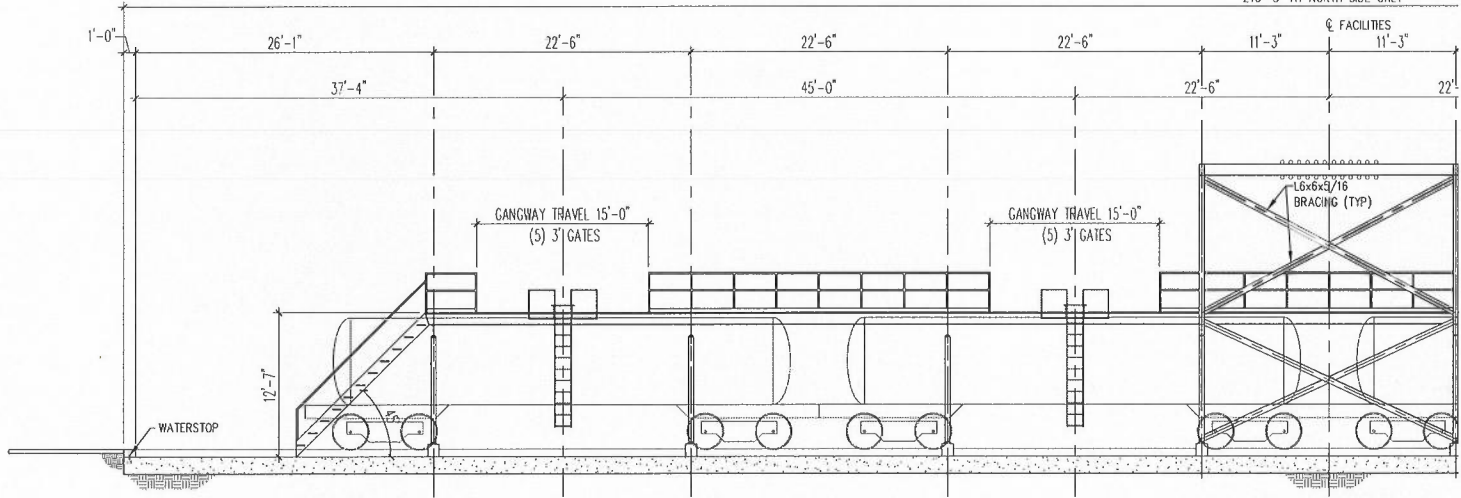

LOOKING NORTHWEST

1
S2.2

SECTION

1/8" = 1'-0"

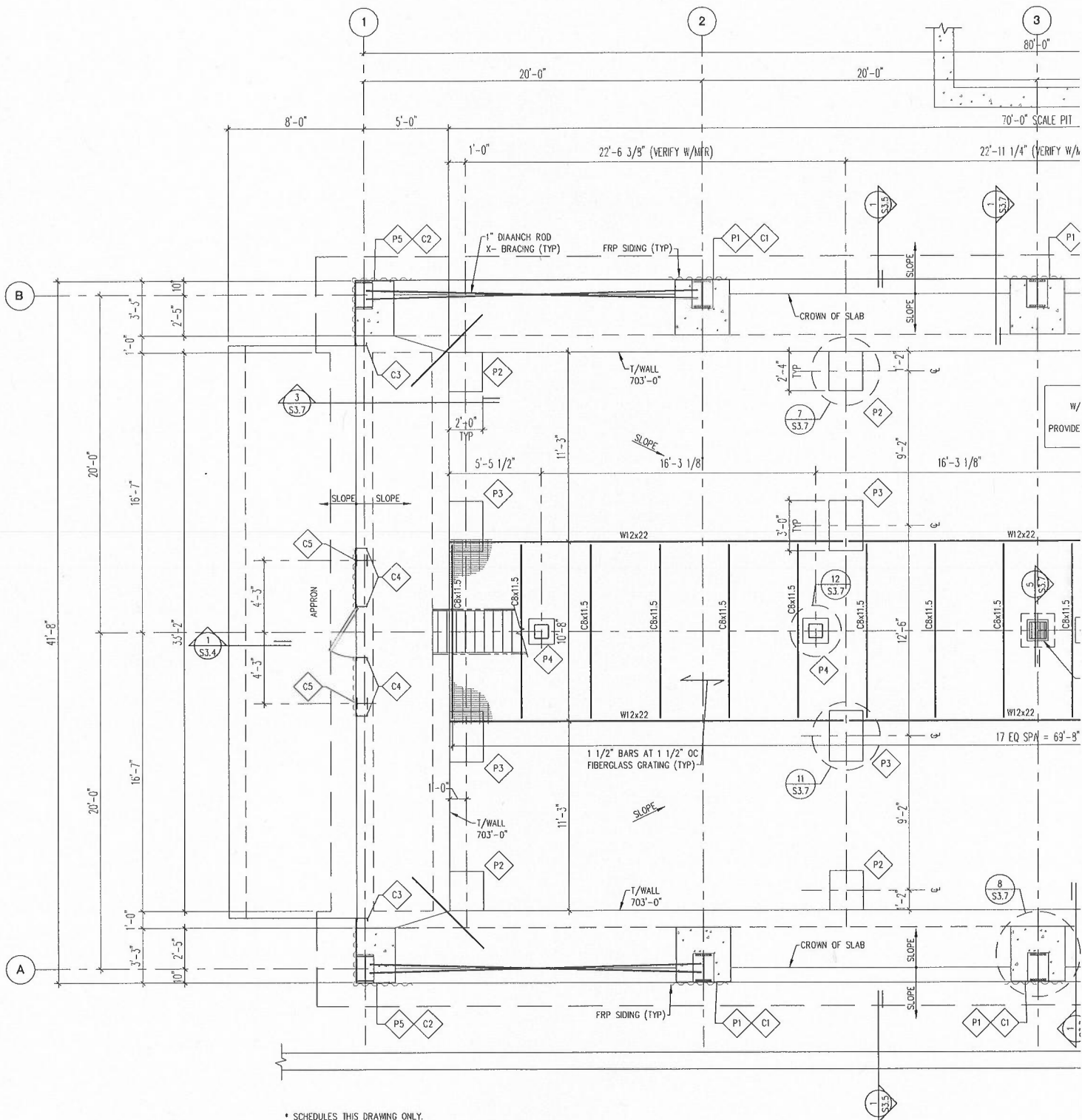

* SCHEDULES THIS DRAWING ONLY.

*COLUMN SCHEDULE		
MARK	DESCRIPTION	BASE PLATE SIZE
C1	W18x119	1'x20"x15" W/ (4) 1" ANCHOR BOLTS
C2	W18x76	1'x20"x12" W/ (4) 1" ANCHOR BOLTS
C3	C8x11.5	3/4" x 8" x 8" W/ (2) 3/4" ANCHOR BOLTS
C4	C8x11.5	SEE DETAIL.....
C5	W8x35	SEE DETAIL.....

*PIER SCHEDULE	
MARK	SIZE & REINFORCING
P1	3'-3" x 3'-3" W/(15) #7 BARS VERT & #3 TIES AT 12" OC
P2	2'-0" x 2'-4" W/(12) #6 BARS VERT & #3 TIES AT 12" OC
P3	2'-0" x 3'-0" W/(12) #5 BARS VERT & #3 TIES AT 12" OC
P4	1'-4" x 1'-4" W/(4) #6 BARS VERT & #3 TIES AT 12" OC
P5	2'-3" x 3'-3" W/(12) #6 BARS VERT & #3 TIES AT 12" OC

TRUCK CONTAINMENT-FOUR

1/4" = 1'-0"

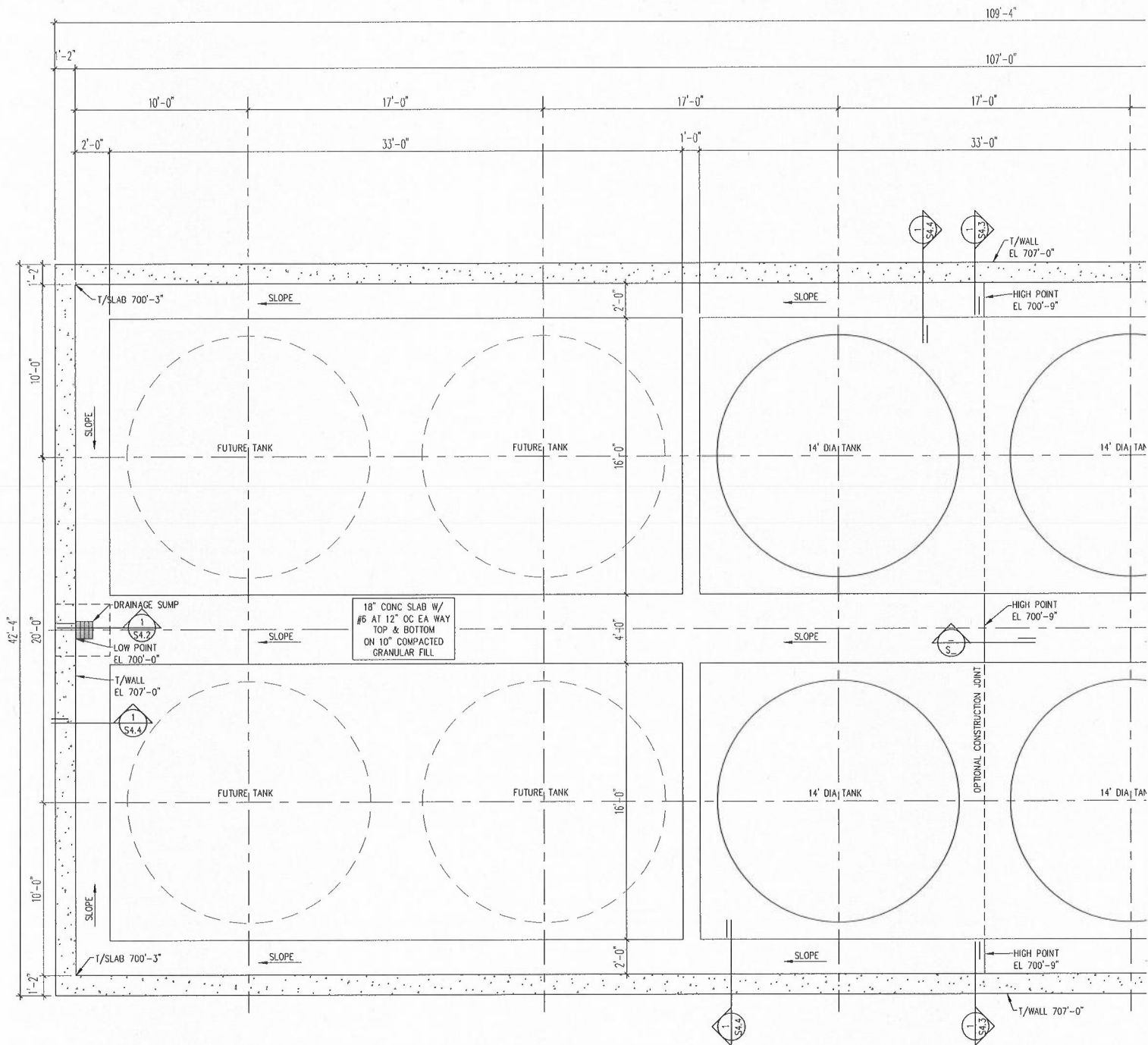

TANK CONTAINMENT FOUNDATION I

1/4" = 1'-0"

TANK CONTAINMENT

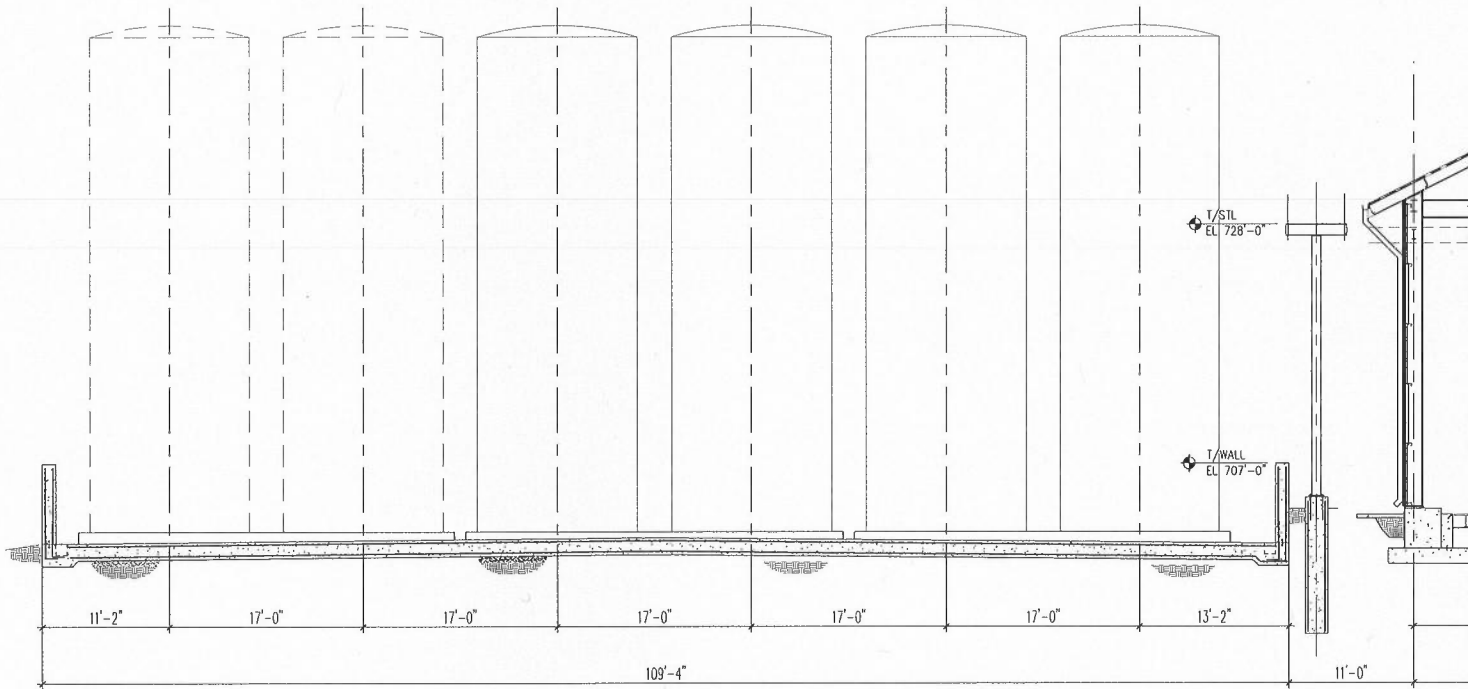

1 OVERALL ELEVATION
S5.0
1/8" = 1'-0"