

SITE LEASE AGREEMENT

Between BOARD OF WATER COMMISSIONERS OF THE CITY OF SAINT PAUL and ZAYO BANDWIDTH, LLC

This Lease Agreement ("Lease") is entered into this 10th day of May, 2011, between the **BOARD OF WATER COMMISSIONERS OF THE CITY OF SAINT PAUL**, a Minnesota municipal corporation ("Lessor"), and **ZAYO BANDWIDTH, LLC**, a Delaware Limited Liability Company ("Lessee").

In consideration of the terms and conditions of this Lease, the parties agree as follows:

1. Leased Premises.

Lessor hereby leases to Lessee certain space located at Lessor's St. Anthony Water Tower located at 1515 North Cleveland Avenue, St. Paul, Minnesota 55116. The water storage facility and its appurtenances ("Structure"), and the Lessor's land upon which the Structure is situated are collectively called the "Property". The property interest leased and granted by the Lessor to Lessee (collectively, the "Leased Premises") consists of the following:

- space inside the compound comprised of approximately 4' x 3', 12 usable square feet;
- space required for cable runs to connect equipment;
- non-exclusive easements required to run utility lines and cables;
- a non-exclusive easement across the Property for access.

No other space or property interests are being leased to Lessee except as described above and as described on Exhibit "A," *Legal Description and Site Plan*.

2. Terms/Renewals.

- (a) The initial term of this Lease shall commence on first day of the month following Saint Paul City Council approval, (the "Commencement Date"), and shall expire on December 31, 2016. Lessee and Lessor agree to enter into an addendum to this Lease confirming the Commencement Date, as contained in Exhibit "E," *Memorandum of Lease Recording*, attached hereto and incorporated herein.
- (b) Lessee shall have the right to extend this Lease for three (3) additional five (5) year terms (each a "Renewal Term") subject to (c) below.
- (c) This Lease shall automatically be renewed for each successive Renewal Term unless Lessee is in default beyond applicable notice and cure periods of any of the terms or conditions of this Lease, or unless Lessee notifies Lessor of its intention not to renew prior to commencement of the succeeding Renewal Term.

3. Rent.

Rent shall consist of Base Rent and such Additional Rent as may apply. Lessee shall make all payments of Base Rent and Additional Rent to Lessor at the following address:

Board of Water Commissioners
Attn: Accounting
1900 Rice Street, Office Building
Saint Paul, Minnesota 55113

Lessor's FIN number is # 41-6005521.

Lessee shall pay all rent annually in advance, as indicated in the payment schedule below:

(a) Base Rent

Lessee shall pay Lessor, as rent, the sum of Five Thousand Forty Dollars (\$5,040.00) per year ("Annual Rent") based upon Lessee's installation and operation of the facilities identified in Exhibit "B," *Facilities*, ("Facilities"), attached hereto and incorporated herein.

The first year's Annual Rent shall be pro-rated to the end of 2011, and shall be paid within sixty (60) days after the Commencement Date. Thereafter, the Annual Rent due hereunder shall be paid prior to January first of each succeeding year.

Lessee may not install and/or operate any additional or related equipment beyond those Facilities identified in Exhibit "B," *Facilities* without the prior written consent of Lessor, such consent not to be withheld, conditioned or delayed without cause.

(b) Annual Increase

Commencing January 1, 2012, and on January 1st of each subsequent year, the Annual Rent shall be increased annually by five percent (5%).

(c) Additional Rent

Additional Rent means all amounts, other than Base Rent provided for in paragraph 3 (a) above, that Lessee shall be obligated to pay under this paragraph or any other paragraph of this Lease. Additional Rent shall include the following fees, costs and expenses:

- (1) costs for the repairs, improvements, or alterations required to be made by Lessee in *Section 6. Maintenance and Repairs*;
- (2) all general, or special taxes on Lessee's personal property. As a condition of Lessee's obligation to pay any tax, Lessor shall provide Lessee documentation from the taxing authority indicating with reasonable certainty that the tax was directly attributable to Lessee's tenancy. Lessee shall have the right to file an assessment appeal, and Lessor shall cooperate in any such appeal as reasonably requested by Lessee, all at Lessee's sole cost and expense;
- (3) all public utility rates, dues, and charges of any kind for utilities used by Lessee at the Leased Premises; and
- (4) fees, costs, and expenses for property insurance and/or uninsured losses as set forth in *Section 13. Insurance*.

In the event that Lessee does not pay the required Additional Rent to the appropriate party, Lessor may, at its option, and after thirty (30) days prior written notice to Lessee, make such payments. Upon Lessor's notice to Lessee that it has made these payments, those amounts become due and payable by Lessee within thirty (30) days.

4. Use of Leased Premises.

(a) Primary Use of Property

The primary use and purpose of the Property, including the Leased Premises, is for a water storage structure and appurtenances to provide water service to customers of the Lessor ("Primary Use"). Lessor's operations in connection with pursuit of the Primary Use ("Lessor's Operations") take priority over Lessee's operations.

(b) Jeopardy of Primary Use

(1) In the event that the Lessor's Primary Use of the Structure is put at risk because of Lessee's operations ("Jeopardy"), Lessor shall provide written notice of such event to Lessee. Lessor and Lessee agree to work together to cure the occurrence that causes the Jeopardy. Lessee shall make all good efforts to cure the Jeopardy within thirty (30) days of receipt of written notice of event. If Lessee does not cure the Jeopardy within thirty (30) days of receipt of written notice of event, said occurrence of Jeopardy shall constitute an event of default by Lessee, as otherwise defined in *Section 12. Termination*. If circumstances beyond the control of Lessee prohibit the Jeopardy from reasonably being cured within thirty (30) days, Lessee shall notify Lessor of such circumstances and commence actions required to cure the Jeopardy (e.g. assessing the problem, ordering necessary equipment) within seven (7) days of Lessor's written notice of Jeopardy and shall diligently pursue the cure to completion within a reasonable time thereafter.

(2) In the event of Jeopardy that poses an immediate threat of substantial harm or damage to the water supply, to persons, and/or property on the Leased Premises, as solely determined by Lessor ("Severe Jeopardy"), Lessor may enter the Leased Premises and take actions it determines are required to protect the water, individuals or personal property from such Severe Jeopardy; provided that promptly after such emergency entry onto the Leased Premises, and in no event later than twenty-four (24) hours after such entry, Lessor gives written notice to Lessee of Lessor's emergency entrance.

(3) If Lessor determines that the conditions of a Severe Jeopardy would be benefited by cessation of Lessee's operations, Lessee shall immediately cease its operations on the Premises upon notice from Lessor to do so.

(c) Lessee's Use of Leased Premises

(1) Lessee shall have the non-exclusive right, at its sole cost and expense, to use the Leased Premises as a telecommunications facility ("Approved Use").

(2) In accordance with this Approved Use, the Lessee has the right to install, operate, maintain, repair, replace, store or remove its utility building, equipment, personal property, leasehold improvements, and appurtenances (collectively, "Facilities") as shown in Exhibit "B", *Facilities* and attached Exhibit "A", *Legal Description and Site Plan*.

(d) Laws Governing Use

Lessee shall use the Leased Premises only in accordance with good engineering practices and in compliance with all applicable Federal Communications Commission (“FCC”) federal, state, and local rules, laws and regulations. This Lease is contingent upon Lessee receiving all permits, licenses or approvals from all local, state, or federal land use jurisdictions or agencies for Lessee’s Approved Use. Lessee shall, at its sole cost and expense, obtain all such necessary permits, licenses or approvals. Lessor agrees to cooperate with Lessee in Lessee’s pursuit of all such necessary permits, licenses or approvals, and Lessee shall reimburse Lessor its reasonable costs to provide such cooperation.

5. **Installation of Equipment and Leasehold Improvements.**

(a) Construction Plans

For the initial installation of all Facilities and for any and all subsequent revisions and/or modifications thereof, or additions thereto, Lessee shall provide Lessor and Lessor’s Water Tower Construction Engineer (“Construction Engineer”) each with two (2) sets of construction plans (“Construction Plans”) consisting of the following:

- 1) line or CAD drawings showing location of all planned installations plus materials and construction methods;
- 2) specifications for all planned installations;
- 3) diagrams of proposed Facilities;
- 4) a complete and detailed inventory of all equipment and personal property of Lessee.

Construction Plans shall be easily readable and subject to prior written approval by the Construction Engineer, which shall not be withheld, conditioned or delayed without cause. Lessor shall have thirty (30) business days to review the Construction Plans. If Lessor fails to either approve the Construction Plans or provide written request for changes of said Construction Plans to Lessee within the thirty (30) day period, the Construction Plans will be deemed approved.

Lessee shall be solely responsible for all costs associated with said review and approval of Construction Plans by Construction Engineer.

(b) Construction Scheduling

At least three (3) days prior to Lessee’s construction mobilization, Lessee shall conduct a pre-construction meeting on the Property. Said meeting shall be attended by the Construction Engineer, Lessee’s representative and all parties involved in the installation. At the pre-construction meeting, the Construction Engineer shall determine and communicate the level of inspection required for each installation.

(c) Construction Inspection.

All construction activity shall be subject to inspection and approval by the Construction Engineer. If inspection and approval of any activity is deemed necessary by the Construction Engineer, such activity not inspected and approved by the Construction Engineer will not be accepted and shall be removed or uninstalled at Lessee’s sole expense. Lessee shall be solely responsible for all costs associated with said inspection and approval of construction work by Construction Engineer.

(d) Exposed Facilities

All Facilities affixed to the Structure which have exterior exposure shall be as close to the color of the Structure as is commercially available to the Lessee. For exposed coaxial cables, Lessor reserves the right to require Lessee to provide cables in manufactured colors in lieu of painting.

(e) Damage by Lessee

Any damage to the Property, Leased Premises, or Lessor's equipment thereon caused by Lessee's installation or operations shall be repaired or replaced at Lessee's expense and to Lessor's reasonable satisfaction.

6. Maintenance and Repairs.

(a) Property

Lessor reserves the right to take any action it deems necessary, in its sole and reasonable discretion, to repair, maintain, alter, or improve the Property in connection with Lessor's Operations.

(b) Structure Reconditioning and Repairs

1. From time to time, Lessor paints, reconditions, or otherwise improves or repairs the Structure in a substantial way ("Reconditioning Work"). Lessor shall reasonably cooperate with Lessee to carry out Reconditioning Work activities in a manner that minimizes interference with Lessee's Approved Use.
2. Prior to commencing Reconditioning Work, Lessor shall provide Lessee with not less than sixty (60) days prior written notice thereof. Upon receiving such notice, it shall be the sole responsibility of Lessee to provide adequate measures to cover or otherwise protect Lessee's Facilities from the consequences of such activities, including but not limited to paint and debris fallout. Lessor reserves the right to require Lessee to remove all Facilities from the Structure and Leased Premises during Reconditioning work.
3. During Lessor's Reconditioning Work, Lessee may maintain a mobile site on the Property or, after approval by Lessor, on any land owned or controlled by Lessor in the immediate area of the Property.
4. Lessee may request a modification of Lessor's procedures for carrying out Reconditioning Work in order to reduce the interference with Lessee's Approved Use. If Lessor agrees to the modification, Lessee shall be responsible for all incremental cost related to the modification.
5. For minor repairs or maintenance, Lessor agrees to provide Lessee with five (5) days advance notice of any such activities and to reasonably cooperate with Lessee to carry out such activities in a manner that minimizes interference with Lessee's Approved Use.

(c) Leased Premises

Lessee shall, at its own cost and expense, maintain the Facilities in good and safe condition, and in compliance with applicable fire, health, building, and other life safety codes.

7. **Property Access.**

Access to the Property, including the Leased Premises, by outside persons, including Lessee's employees, agents and assigns, shall at all times be governed by Lessor's Remote Facilities Access Plan and Procedures, attached hereto and incorporated herein as Exhibit "C", *Security Plan*. Lessee agrees it shall conduct its operations on the Property and the Leased Premises in accordance with all requirements and conditions of said Security Plan. Subject to said requirements and conditions of said Security Plan, Lessee and Lessor agree to the following:

- (a) Lessee shall have access to the Leased Premises and Property twenty-four (24) hours a day, seven (7) days a week by means of existing access for any purpose relating to this Lease.
- (b) Lessee may, at its own cost and expense, enter upon the Property to study and determine the Property's suitability for any other use of Lessee, which studies may include surveys, radio wave propagation measurements, or field strength tests.
- (c) Lessor retains the right to examine and inspect the Leased Premises for safety reasons and to ensure that Lessor's covenants are being met. Lessor shall be liable for, and hold harmless Lessee from, any damage to the Leased Premises or to Lessee's equipment and Facilities caused by Lessor in exercising its right to examine and inspect the Leased Premises.

8. **Utilities.**

Lessor makes no representations that utilities adequate for Lessee's use of the Leased Premises are available. Lessee shall be responsible for the cost of all utilities installed and used by it at the Leased Premises. Lessor will cooperate with Lessee in Lessee's efforts to obtain utilities from any location provided by the servicing utility.

9. **Personal Property and Real Estate Taxes.**

If any of Lessee's improvements constructed on the Leased Premises should cause the Property, or any portion of it, to be taxed for real estate purposes, it shall be the liability of Lessee to pay that portion of such property taxes directly attributable to Lessee's equipment, provided Lessor shall give Lessee prior written notification of such taxes so that Lessee will have the opportunity to appear before the taxing authority to contest such taxes. Notwithstanding Lessee's right to contest such taxes, Lessee shall pay its share of such taxes within ninety (90) days of receiving notice of the same.

10. **Compliance and Statutes, Regulations, and Approvals.**

Lessee's use of the Leased Premises herein is contingent upon its obtaining all certificates, permits, zoning, and other approvals that may be required by any federal, state or local authority. Lessee's Facilities and any other facilities shall be installed, maintained, and operated in accordance with all state or federal or local or municipal statutes, ordinances, rules, or regulations now in effect, or that hereafter may be issued by the FCC or any other governing bodies.

11. **Interference.**

- (a) In the performance of its Approved Use, Lessee shall not damage or interfere with Lessor's Operations, including its radio frequency transmissions, or approved operations of other parties that were tenants on the Property prior to the Commencement Date of this Lease, provided that the equipment used by Lessor or other tenants is operating within the technical perimeters specified by its manufacturer and/or as defined by the FCC. In the event of any such interference, Lessee shall take all actions necessary to immediately eliminate such interference in accordance with reasonable technical standards. In the event Lessee cannot correct the interference, Lessee shall have the option to terminate this Lease, pursuant to *Section 12. Termination*. Lessee shall not be responsible for interference that results from a change in the operations of other tenants after the Commencement Date of this Lease.
- (b) Lessor will not grant a lease to any other party for use of the Property, if such use would, or would likely, interfere with Lessee's Approved Use. Any future lease by Lessor of the Property to additional parties that permits the installation of communications equipment shall be conditioned upon not interfering with Lessee's Approved Use. Notwithstanding the foregoing, Lessee acknowledges that Lessor may lease the Property, or any part of it, to other parties in close proximity to the Leased Premises, and Lessee agrees to work cooperatively with any such other parties, using accepted technical standards in accordance with FCC standards, to ensure that such other parties' use and Lessee's use will be compatible and will not cause interference with each other. Lessor agrees that it will require the same obligation of all such future parties in any lease or agreement with such future parties.
- (c) Lessor in no way guarantees to Lessee noninterference with Lessee's transmission operations, provided, however, that in the event that any other party requests permission to place any type of additional facility on the Property, the procedures of this Section shall govern to determine whether such transmission facility will interfere with Lessee's transmission operations.

In the event Lessor receives any such request or proposal from a party seeking to lease space on the Property, Lessor shall submit the proposal, complete with all technical specifications reasonably requested by Lessee, to Lessee for review for noninterference. Lessee shall have thirty (30) days following receipt of said proposal to make any objections thereto, and failure to make any objection within said thirty (30) day period shall be deemed consent by Lessee, subject to interference provisions of paragraph 11(c) of this Lease, to the installation of transmission facilities pursuant to said proposal. Lessee shall not be responsible for the expenses incurred in any independent validation of such interference objections.

- (d) In the event that Lessee or other tenants on the Property experience interference of their approved frequencies and they cannot reach agreement as to the cause and remedy of such interference, the RF Engineer shall determine such cause and remedy and Lessee shall abide by the RF Engineer's determination. Lessor agrees that it will require the same obligation of all such future parties in any lease or agreement with such other parties.

12. Termination.

Except as otherwise provided herein, this Lease may be terminated by either party upon sixty (60) days written notice [except under 12.(c)(2)] to the other party for the following reasons:

- (a) By either party, upon a material default of any other covenant or term hereof by the other party; which default is not cured within sixty (60) days of receipt of written notice of default to the other party (without, however, limiting any other rights of the parties at law, in equity, or pursuant to any other provisions hereof), or if such cure cannot be completed within sixty (60) days, within such reasonable time as may be required, provided the defaulting party commences the cure within ten (10) days of receipt of written notice of default and diligently pursues such cure to completion;
- (b) By Lessee, in the event that:
 - (1) Lessee is unable to obtain or maintain any license, permit, or other governmental approval necessary for the construction and/or operation of the Facilities;
 - (2) the Leased Premises are or become unusable under Lessee's design or engineering specifications for its Facilities, or the communications system to which the Facilities belong; or
 - (3) Lessee's transmission is interfered with by Lessor or its other tenants' equipment. Such right to terminate shall become void if Lessor cures such interference within thirty (30) days of receipt of written notice.
- (c) By Lessor, in the event that:
 - (1) Lessor determines, after review by an independent structural engineer, that the Property is structurally unsound, including but not limited to consideration of age of the Structure, damage or destruction of all or part of the Property from any source, or factors relating to condition of the Property;
 - (2) Lessee fails to pay rent provided for in *Section 3. Rent* within thirty (30) days of receipt of written notice from Lessor of a rent or other payment being overdue; or
 - (3) Lessee does not complete installation of its Facilities as shown on Exhibit "B", *Facilities* within one (1) year of the Commencement Date of this Lease.

If this Lease is terminated, pursuant to the terms and conditions of this Lease, rent shall be pro-rated to the expiration date or the date on which all of Lessee's equipment is removed from the Leased Premises, whichever is later [in the event of Termination under Sections 12.(a) by Lessee, 12.(c)(2), or 12.(c)(3)], or whichever is earlier (in the event of Termination under any other Section). Within thirty (30) days after the date of the termination, Lessor shall, if applicable, return to Lessee any amounts that Lessee has prepaid to Lessor.

13. Insurance.

- (a) Lessee shall obtain and maintain adequate insurance to protect the parties against any and all claims, demands, actions, judgments, expenses, and liabilities that may arise out of or result from Lessee's use of the Leased Premises. Any applicable liability policy shall list the Lessor and the City of Saint Paul as additional insured, and shall provide that it will be the primary coverage. The insurance coverage must include, at a minimum, Comprehensive General Liability Insurance Coverage, including premises/operation coverage, bodily injury, property damage, independent contractors liability, completed

operations coverage, and contractual liability coverage, in a combined single limit of not less than One Million Five Hundred Thousand Dollars (\$1,500,000) per occurrence, subject to Three Million Dollars (\$3,000,000) aggregate. Lessee may satisfy this requirement with underlying insurance and/or an umbrella policy.

- (b) Lessee shall provide Lessor, prior to the Commencement Date and before each Renewal Term of this Lease, evidence of the required insurance in the form of a certificate of insurance issued by an insurance company licensed to do business in the State of Minnesota, which includes all coverage required in paragraph 13(a) above. Said certificate shall also provide that the coverage may not be canceled, or non-renewed, or materially changed without thirty (30) days written notice to Lessor.

14. Indemnity.

Lessee agrees to indemnify, defend, save, and hold harmless Lessor and the City of Saint Paul, and/or any agents, officers or employees thereof from all claims, demands, actions, or causes of action of whatsoever nature or character, arising out of, or by reason of, the leasing of the Leased Premises by the Lessor to Lessee, or arising out of, or by reason of, the use or condition of the Leased Premises, or as a result of Lessee's operations or business activities taking place on the Leased Premises, provided the same is not due to the contributory negligence or willful misconduct of the Lessor, the City of Saint Paul and/or any agents, contractors, officers, or employees thereof. It is fully understood and agreed that Lessee is aware of the conditions of the Leased Premises and leases the same "as is."

15. Damage or Destruction.

If the Property or any portion thereof is destroyed or damaged so as to hinder its effective use, Lessee may elect to terminate this Lease upon thirty (30) days written notice to Lessor. In such event, all rights and obligations of the parties shall cease as of the date of the damage or destruction and Lessee shall be entitled to the reimbursement of any rent prepaid by Lessee, prorated to the date of the event.

16. Notices.

All notices, requests, demands, and other communications hereunder shall be in writing and shall be deemed given when personally delivered or mailed, certified mail, return receipt requested, to the following addresses:

If to Lessor: Board of Water Commissioners
 Attn: General Manager
 1900 Rice Street, Office Building.
 Saint Paul, Minnesota 55113

If to Lessee: Zayo Bandwidth, LLC
 400 Centennial Parkway
 Suite 200
 Louisville, CO 80027
 Attn: General Counsel

With a Copy To: Zayo Bandwidth, LLC
400 Centennial Parkway
Suite 200
Louisville, CO 80027
Attn: Lease Administrator

17. Representations and Warranties.

- (a) Lessor represents that (i) it has full right, power, and authority to execute this Lease; (ii) it has good and unencumbered title to the Property free and clear of any liens or mortgages, subject to such liens of record; (iii) Lessee shall have quiet enjoyment of the Leased Premises during the term of this Lease in accordance with its terms.
- (b) Lessee warrants that the individuals signing and executing this Lease on behalf of Lessee have the requisite corporate power and authority to enter into and perform this Lease on behalf of Lessee.
- (c) Lessor represents that it has no knowledge of any substance, chemical or waste on the Property that is identified as hazardous, toxic or dangerous in any applicable federal, state or local law or regulation as defined in paragraph 17 (d) of this Lease. Lessor will be solely liable for and will defend, indemnify and hold Lessee, its agents and employees harmless from and against any and all direct claims, costs and liabilities, including reasonable attorneys' fees and costs, arising out of or in connection with the removal, cleanup or restoration of the Property with respect to hazardous, toxic or dangerous materials from any and all sources other than those hazardous, toxic or dangerous materials introduced to the Property by Lessee. Lessee represents and warrants that its use of the Leased Premises herein will not generate and it will not store or dispose on the Property nor transport to or over the Property any hazardous substance, chemical or waste contrary to any law or regulation. Lessee further agrees to hold Lessor harmless from and indemnify Lessor against any release of any such hazardous substance by Lessee, and any damage, loss, expense, or liability resulting from the breach of this representation or from the violation of any state or federal law by such release associated with Lessee's use of hazardous substances, including payment of all reasonable attorneys' fees, costs, and penalties incurred as a result thereof, except for any release caused by the acts or omissions of Lessor, its employees, or agents. Lessee's hazardous material liability and indemnification of Lessor shall survive termination or expiration of this Lease.
- (d) "Hazardous substance" shall be interpreted broadly to mean any substance or material defined or designated as hazardous or toxic waste, hazardous or toxic material, hazardous or toxic or radioactive substance, or other similar term by any federal, state, or local environmental law, regulation or rule presently in effect or promulgated in the future, as such laws, regulations, or rules may be amended from time to time. Lessor acknowledges Lessee's use of batteries as back-up power and deems them acceptable as long as such batteries are used and disposed of in accordance with all applicable laws and good engineering practices.

18. No Liability on Lessor.

Except due to Lessor's willful misconduct or gross negligence, Lessor shall not be liable for any damage to Lessee's equipment or Facilities, and Lessor shall not be liable for vandalism or malicious mischief caused by third parties, known or unknown, to Lessee's equipment or facilities, nor shall Lessor be liable for any lost revenue, business or profits of Lessee.

19. Assignment.

- (a) Lessee may not assign or sublet this Lease without the prior written consent of Lessor, which consent shall not be withheld or delayed without reasonable cause. Notwithstanding the provisions of this paragraph, as long as assignee assumes the obligations of this Lease, Lessee's interest under this Lease may be sold, assigned or transferred by the Lessee without any approval or consent of the Lessor to: (a) any entity controlling, controlled by or under common control with Lessee; (b) any entity acquiring substantially all of the assets of Lessee; or (c) any successor entity in a merger or consolidation involving Lessee (collectively, "Permitted Assignment"). Lessee shall provide Lessor written notice of such assignments within thirty (30) days of execution. As to other parties, this Lease may not be sold, assigned or transferred without the written consent of the Lessor, which such consent will not be withheld, conditioned or delayed without cause. Lessee acknowledges and agrees that other than a Permitted Assignment, no assignment, sublease or other transfer of the Lessee's rights under this Lease shall serve to constitute a release of the original named Lessee and/or the then current Lessee. Any approved sublease that is entered into by Lessee shall be subject to all of the provisions of this Lease.
- (b) The parties acknowledge that this is a nonexclusive lease. Nothing in this Lease shall preclude Lessor from leasing other space on the Property to any other person or entity which may be in competition with Lessee, or any other party, subject to the conditions set forth in *Section 11. Interference*.

20. Successors and Assigns.

This Lease shall run with the Property. This Lease shall be binding upon and inure to the benefit of the parties, their respective successors, personal representatives and assigns.

21. Surrender of Premises.

At the expiration of the initial term of this Lease, or any Renewal Term, or any earlier termination of this Lease, Lessee shall quit peacefully and surrender possession of the Leased Premises in as good condition as when it was delivered to Lessee, reasonable wear and tear and casualty loss excepted. Lessee shall remove its equipment, personal property, Facilities, and leasehold improvements from the Property within thirty (30) days of expiration or termination, and shall repair any damage to the Property caused by such equipment, all at Lessee's own cost and expense.

22. Marking and Lighting Requirements.

Lessor acknowledges that it shall be responsible, at its sole cost and expense, for compliance with all building marking and lighting requirements that the Federal Aviation Administration ("FAA") may require with respect solely to the height of the Structure. The responsibility, however, is expressly limited to the requirements that would be required of an elevated water storage facility having no communications equipment installed on it, irrespective of Lessee's Facilities. Lessor shall indemnify and hold harmless Lessee from any fines or other liabilities caused by Lessor's failure to comply with such requirements for an elevated water storage facility Structure. Further, should the FAA cite Lessor, or in the event any claims are brought against Lessor because the Structure alone is not in compliance, as opposed to the Structure with Facilities, then Lessor shall indemnify Lessee for full costs, liabilities, damages and expenses, including reasonable attorney's fees. Further, if Lessor does not cure

the conditions of noncompliance on the Structure within the time frame allowed by the citing agency, Lessee may terminate this Lease immediately without any further liability hereunder upon written notice to Lessor.

23. RF Radiation Compliance.

Lessee shall implement all measures at the transmission site required by FCC regulations, including but not limited to posting signs and markings. Lessor shall cooperate with and permit Lessee to implement all reasonable measures in order for Lessee to fulfill its Radio Frequency exposure obligations. Lessor agrees that in the event any future party causes the entire site to exceed FCC Radio Frequency radiation limits, as measured on the Premises, Lessor shall hold such future party liable for all such later-arising non-compliance.

24. Third Party Approvals, Inspections and Evaluations.

The Lessee shall be responsible for all costs associated with obtaining required reviews, approvals, inspections, studies surveys or evaluations, whether required by this Lease or by other governing authorities.

25. Noise Restrictions.

Noise from Lessee's equipment shall not exceed the level allowed by the city's Department of Safety and Inspections (55 decibels at commencement of lease), as measured at any location on neighboring property ("Allowable Noise Level"). Lessor will take noise level measurements from time to time to verify compliance. In the event it is found that Lessee's equipment exceeds the Allowable Noise Level, Lessor shall provide Lessee with written notice and Lessee shall take immediate steps to provide permanent reduction in the noise of its equipment to the Allowable Noise Level.

If Lessee does not so reduce its Measured Sound Level within sixty (60) days of receipt of written notice of event, said occurrence shall constitute an event of default as otherwise defined in Lease paragraph 12, *Termination*.

26. Miscellaneous.

(a) Each party agrees to furnish to the other, within thirty (30) days after notice of receipt of the request, such truthful estoppel information as the other party may reasonably request.

(b) This Lease constitutes the entire agreement and understanding of the parties and supersedes any and all offers, negotiations, or other agreements of any kind. There are no representations or understandings of any kind not set forth herein. Any modification or amendment to this Lease must be in writing and executed by both parties. No provision of this Lease will be deemed waived by either party unless expressly waived in writing by the waiving party. No waiver shall be implied by delay or any other act or omission of either party. No waiver by either party of any provisions of this Lease shall be deemed a waiver of such provision with respect to any subsequent matter relating to such provision. This Lease may be executed in multiple counterparts, each of which shall be deemed an original, but all of which together shall constitute a single instrument.

(c) This Lease shall be construed in accordance with the laws of the State of Minnesota. Any legal action may only be commenced and proceed in the relevant district court in Ramsey County, Saint Paul, Minnesota.

- (d) If any term of this Lease is found to be void or invalid, such invalidity shall not affect the remaining terms of this Lease, which shall continue in full force and effect.
- (e) Upon request by Lessee, Lessor agrees to execute a recordable Memorandum of this Lease.
- (f) Exhibits “A” through “E” listed below are hereby incorporated into this Lease by reference.

Exhibit “A” *Legal Description and Site Plan*

Exhibit “B” *Facilities*

Exhibit “C” *Remote Access Plan*

Exhibit “D” *Technical Minimum Site Standards – Not Applicable*

Exhibit “E” *Memorandum of Lease Recording*

[Remainder of this page is left intentionally blank]

IN WITNESS WHEREOF, the parties hereto have executed this Lease, the day and year first above written.

For Lessor:

Approved:

By _____
Stephen P. Schneider, General Manager
Saint Paul Regional Water Services

Approved as to form:

By _____
Assistant City Attorney

**BOARD OF WATER COMMISSIONERS
OF THE CITY OF SAINT PAUL**
FIN # 41-6005521

By _____
Patrick Harris, President

By _____
Mollie Gagnelius, Secretary

CITY OF SAINT PAUL:

By _____
Paul Williams, Deputy Mayor

By _____
Shari Moore, City Clerk

By _____
Todd Hurley, Acting Director
Office of Financial Services

For Lessee:

Approved:

By _____
Its Legal Counsel

ZAYO BANDWIDTH, LLC
Tax ID # _____

By _____

Its _____

EXHIBIT "A"

Legal Description and Site Plan

Lots one (1) and two (2) all in Block one (1) of St. Anthony Park North, according to the record plat thereof on file and of record in the office of the Register of Deeds in and for the County of Ramsey, State of Minnesota.

EXHIBIT "A"

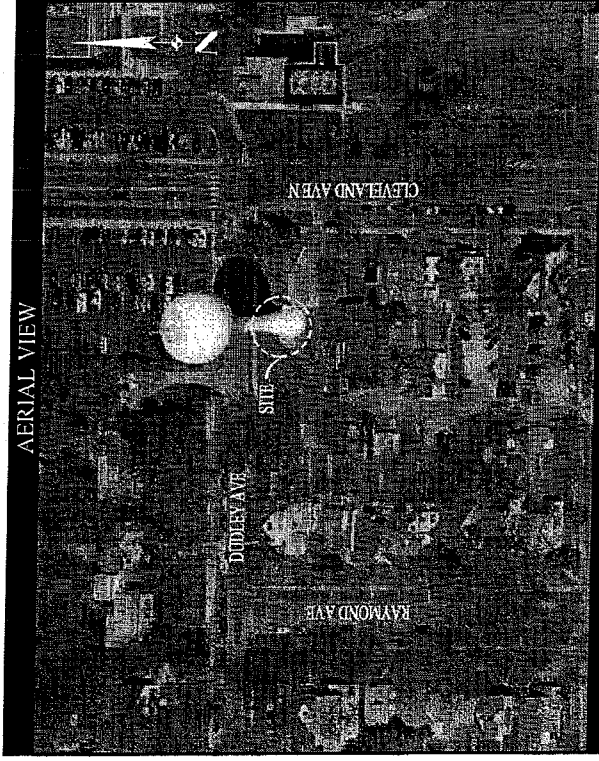

AERIAL VIEW

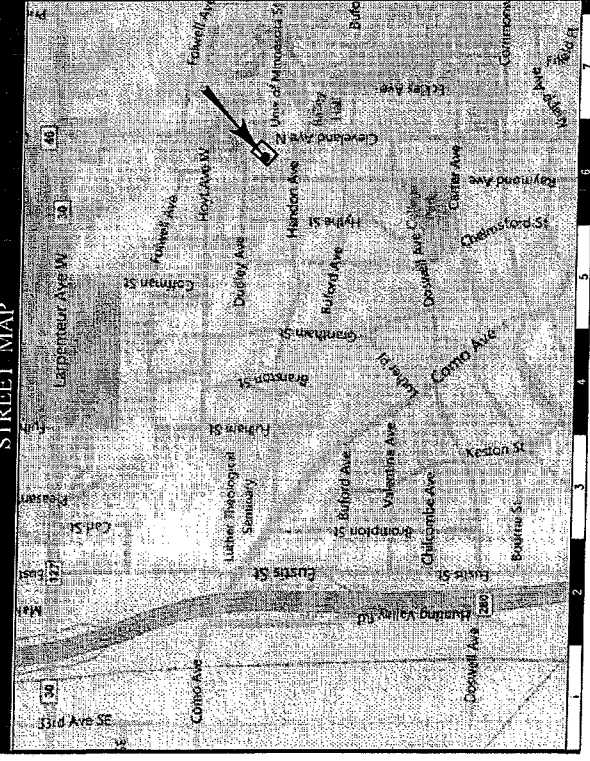

STREET MAP

1515 N Cleveland Ave
AIN0929A
Zayo Utility Project
Saint Paul, Minnesota

Zayo
BANDWIDTH
400 CENTENNIAL PKWY., STE. 200
LOUISVILLE, CO 80027

Plan Date: February 23rd, 2011

TITLE SHEET

Plans Prepared By:

100 WENDELL ROAD, SUITE 100
EAST AURORA, IL 60124
PHONE: 708.917.4993
FAX: 708.925.7138

Borland Civil Engineering
& Land Surveying, LLC
8902 Althea Ct
Indianapolis, IN 46256
Office: 316-6181
borland@civil-llc.com

Rev. No.	Description	Date
1	REV: Rev. Index	12-22-10
2	REV: Rev. Index	2-23-11

REVISION BLOCK

Project Number: 2010-082/AIN0929A
Sheet No.: **C-1**

1515 N Cleveland Ave
AIN0929A
Zayo Utility Project
Saint Paul, Minnesota

PROJECT NARRATIVE

This project proposes to set equipment cabinets and construct underground conduits for data/communications at 1515 N Cleveland Ave, Saint Paul, Minnesota.

PROJECT LOCATION

LATITUDE: 44.98701
LONGITUDE: -93.18753

PLAN INDEX

SHEET	TITLE	RELEASE DATE	REVISION DATE
C-1	TITLE SHEET	10-04-10	2-23-11
C-2	CONSTRUCTION SPECIFICATIONS	10-04-10	12-22-10
C-3	CONSTRUCTION DETAILS	10-04-10	12-22-10
C-3A	CONSTRUCTION DETAILS	10-04-10	12-22-10
C-4	SITE PLAN	10-04-10	2-23-11
C-5	SITE PHOTOGRAPHS	10-04-10	-

GENERAL PLAN NOTES

- Parcel boundaries, easements, and lease areas shown on this plan are based on available GIS and other boundary information. They do not represent boundaries based on a boundary survey.
- Dimensions shown in this plan are based on information provided by others which includes scaled lengths and limited field measurements. Existing improvements have not been field located by measurements taken by a registered land surveyor.

SITE/TOWER OWNER APPROVAL

SITE/TOWER OWNER REPRESENTATIVE SIGNATURE _____ DATE _____

SITE/TOWER OWNER REPRESENTATIVE PRINTED NAME _____ DATE _____

Zayo bandwidth **INSIDE PLANT PLANS**

CONSTRUCTION & GENERAL NOTES

- ALL WORK SHALL BE COMPLETED TO THE STANDARDS SPECIFIED IN THE ZAYO BANDWIDTH INSIDE PLANT/SITE LOCATION MANUAL.
- THE CONTRACTOR SHALL FIELD VERIFY ALL EXISTING CONDITIONS AND PLAN DIMENSIONS, AND SHALL IMMEDIATELY NOTIFY CONSTRUCTION MANAGER AND ENGINEER OF ANY DISCREPANCIES.
- A 20-FOOT HORIZONTAL CLEARANCE SHALL BE MAINTAINED FROM ALL EXISTING POWER LINES.
- THE CONTRACTOR SHALL PROVIDE ALL LABOR, MATERIALS, TOOLS, EQUIPMENT, TRANSPORTATION AND POWER SERVICES NECESSARY FOR AND INCIDENTAL TO COMPLETION OF ALL WORK AS INDICATED ON THE DRAWINGS AND/OR AS SPECIFIED HEREIN.
- THE DRAWINGS ARE DIAGRAMMATIC AND INDICATE THE GENERAL ARRANGEMENT OF SYSTEMS AND EQUIPMENT UNLESS OTHERWISE INDICATED BY DIMENSIONS OR DETAILS. EXACT EQUIPMENT LOCATIONS SHALL BE GOVERNED BY ACTUAL FIELD CONDITIONS AND/OR INSTRUCTIONS OF THE ENGINEER AND/OR OWNERS' REPRESENTATIVE.
- THE CONTRACTOR SHALL FURNISH AND INSTALL ALL MATERIALS AS REQUIRED FOR COMPLETE SYSTEMS, INCLUDING ALL PARTS ORASSEMBLY OR REASONABLY INCIDENTAL TO A COMPLETE INSTALLATION, WHETHER SPECIFICALLY INDICATED OR NOT. ALL SYSTEMS SHALL BE COMPLETELY ASSEMBLED, TESTED, ADJUSTED, AND DEMONSTRATED TO BE READY FOR OPERATION PRIOR TO THE OWNERS' ACCEPTANCE.
- THE CONTRACTOR SHALL OBTAIN, PAY FOR AND DELIVER ALL REQUIRED PERMITS, CERTIFICATES OF INSPECTION, INCLUDING UTILITY CONNECTION FEES, ETC., REQUIRED BY THE AUTHORITIES HAVING JURISDICTION. DELIVER CERTIFICATES TO THE OWNER PRIOR TO FINAL ACCEPTANCE OF THE WORK.
- THE CONTRACTOR OPERATIONS SHALL BE CONFINED TO AREAS OF NEW CONSTRUCTION.
- RESTORATION OF ANY DAMAGE TO THE EXISTING ACCESS ROADWAY AND ANY ADJACENT SITE AS A RESULT OF HIS USE DURING CONSTRUCTION, ALL DISTURBED AND DAMAGED AREAS SHALL BE RESTORED TO THEIR ORIGINAL CONDITION OR BETTER UPON COMPLETION OF ALL WORK.
- THE CONTRACTOR SHALL REMOVE ALL WASTE, DEBRIS AND TRASH FROM SITE AND DISPOSE OF IN A LEGAL MANNER ON A DAILY BASIS.
- PRIOR TO THE SUBMISSION TO HIS BID, THE CONTRACTOR SHALL VISIT THE JOB SITE. THE CONTRACTOR SHALL BE RESPONSIBLE FOR CORRECTING ANY DISCREPANCIES AS SHOWN AND THAT THE WORK MAY BE ACCOMPLISHED AS SHOWN, PRIOR TO PROCEEDING WITH CONSTRUCTION, ANY DISCREPANCIES SHALL BE BROUGHT TO THE ATTENTION TO THE CONSTRUCTION MANAGER.
- FOR ITEMS NOT CLEARLY DENIED OR IDENTIFIED BY THE CONTRACT DOCUMENTS, THE CONTRACTOR SHALL NOT START WORK ON SUCH ITEMS WITHOUT HAVING RECEIVED WRITTEN AUTHORIZATION TO PROCEED.
- THE CONTRACTOR SHALL INSTALL ALL EQUIPMENT AND MATERIALS IN ACCORDANCE WITH THE MANUFACTURERS RECOMMENDATIONS UNLESS SPECIFICALLY INDICATED OTHERWISE IN THE CONTRACT DOCUMENTS

OR WHERE LOCAL CODES OR REGULATIONS TAKE PRECEDENCE.

- ALL WORK PERFORMED AND MATERIALS INSTALLED SHALL BE IN STRICT ACCORDANCE WITH ALL APPLICABLE CODES, REGULATIONS AND ORDINANCES. THE CONTRACTOR SHALL GIVE ALL NOTICES TO COMPLY WITH ALL LAWS, ORDINANCES, RULES, REGULATIONS AND LAWFUL ORDERS OF ANY PUBLIC AUTHORITIES HAVING JURISDICTION OVER THE PERFORMANCE OF THE WORK. MECHANICAL AND ELECTRICAL SYSTEMS SHALL BE INSTALLED IN ACCORDANCE WITH ALL APPLICABLE MUNICIPAL AND UTILITY COMPANY SPECIFICATIONS AS WELL AS LOCAL AND STATE CODES, ORDINANCES AND APPLICABLE REGULATIONS.
- THE CONTRACTOR SHALL SUPERVISE AND DIRECT THE WORK USING THE BEST SKILLS AND INTENTION. THE CONTRACTOR SHALL BE SOLELY RESPONSIBLE FOR ALL OF THE CONSTRUCTION MEANS, METHODS, TECHNIQUES, SEQUENCES AND PROCEDURES AND FOR COORDINATING ALL PORTIONS OF THE WORK UNDER THE CONTRACT INCLUDING CONTACT AND COORDINATION WITH THE PROJECT MANAGER AND THE OWNERS REPRESENTATIVE.
- THE CONTRACTOR SHALL MAKE NECESSARY PROVISIONS TO PROTECT EXISTING IMPROVEMENTS, PAVING, CURBS, GALVANIZED SURFACES, ETC., AND UPON COMPLETION OF WORK, REPAIR ANY DAMAGE THAT OCCURRED DURING CONSTRUCTION TO THE SATISFACTION OF THE PROJECT MANAGER.
- THE CONTRACTOR SHALL KEEP THE GENERAL AREA CLEAN AND HAZARD FREE. DISPOSE OF ALL DIRT, DEBRIS, AND RUBBISH AND REMOVE EQUIPMENT NOT SPECIFIED AS REMAINING ON THE PROPERTY. LEAVE PREMISES IN CLEAN CONDITION AND FREE FROM ANY PAINT SPOTS, DUST, OR SAUDGES OF ANY NATURE.
- ALL CONDUIT SHALL BE 2.00 INCH INSIDE DIAMETER SCH 80 P/VC UNLESS OTHERWISE SPECIFIED ON THE DRAWINGS.
- ALL CONDUIT FITTINGS SHALL BE UL LISTED.
- THE TOP OF ALL BURIED POWER CONDUIT/CABLE WILL BE PLACED 38" BELOW GRADE UNLESS OTHERWISE SPECIFIED ON THE DRAWINGS. THE TOP OF ALL BURIED DATA CONDUIT/CABLE WILL BE PLACED 24" BELOW GRADE UNLESS OTHERWISE SPECIFIED ON THE DRAWINGS.
- ALL 90 DEG CONDUIT SWEEPS SHALL BE MIN 3/8" RADIUS UNLESS OTHERWISE SPECIFIED ON THE DRAWINGS.
- MAXIMUM PULLING TENSION ON CABLES IS 600 LBS.
- PULLING EYE MUST BE USED AND ATTACHED CORRECTLY TO CABLE VIA 600 LB BREAKAWAY SWIVEL.
- GROUND WIRE SHALL BE #2 AND EXOTHERMICALLY BONDED TO THE GROUND RING.
- CONTRACTOR IS RESPONSIBLE FOR SUPPLYING ALL MATERIALS AS SPECIFIED ON THE DRAWINGS.
- THE CONTRACTOR MUST CONTACT LOCAL UTILITY LOCATE SERVICES A MINIMUM 72 HOURS PRIOR TO CONSTRUCTION.
- ALL WORK IN OR ALONG PUBLIC RIGHT-OF-WAY SHALL BE PERFORMED TO THE APPROPRIATE SAFETY STANDARDS. WARNING DEVICES, GUARDS, FLASHERS, FLAGS AND FLAMEN SHALL BE USED AS REQUIRED TO PROVIDE ADEQUATE PROTECTION TO VEHICULAR TRAFFIC, THE PUBLIC AND WORKMEN. STATE LANS, CITY AND COUNTY ORDINANCES RELATIVE TO WORKING HOURS, TRAFFIC CONTROL WARNINGS SIGNALS, COLOR OF CLOES IN FLASHERS, GUARDS, FLAGMEN, ETC., SHALL BE COMPLIED WITH WHEN WORKING ON OR NEAR ANY PUBLIC RIGHT-OF-WAY. ALL DEVICES MUST BE IN

PLACE PRIOR TO THE START OF CONSTRUCTION AND SHALL BE MAINTAINED BY THE CONSTRUCTION CONTRACTOR DURING CONSTRUCTION.

- ALL WORK SHALL BE PERFORMED IN ACCORDANCE WITH OSHA REGULATIONS. PARTICULAR EMPHASIS HAS BEEN PLACED ON THE REQUIREMENT TO SHORE OR SLOPE ALL EXCAVATIONS GREATER THAN FOUR (4) FEET DEEP.
- ALL DIMENSIONS PERTAINING TO BUILDING ENTRANCE FACILITIES AND BUILDING PENETRATIONS ARE APPROXIMATE. IT IS THE SOLE RESPONSIBILITY OF THE CONSTRUCTION CONTRACTOR TO VERIFY ALL DIMENSIONS AT LEAST 5 WORKING DAYS PRIOR TO CONSTRUCTION WITH THE BUILDING OWNER OR THE BUILDING OWNERS REPRESENTATIVE. ANY DAMAGE CAUSED BY THE CONSTRUCTION CONTRACTOR DUE TO NOT NOTIFYING THE PROPER AUTHORITIES WILL BE REPAIRED AT THE SOLE EXPENSE OF THE CONSTRUCTION CONTRACTOR.
- THE CONSTRUCTION CONTRACTOR IS RESPONSIBLE FOR BLOWING AND TESTING ALL MANHOLES PRIOR TO ENTRY. NO OPEN FLAME TORCH, LIGHTED CIGAR, CIGARETTE OR PIPE SHALL BE BROUGHT NEAR OR INTO AN OPEN MANHOLE. THIS RULE SHALL BE OBSERVED EVEN THOUGH TESTS INDICATE THAT THE ATMOSPHERE IS FREE OF COMBUSTIBLE GAS. MANHOLES MUST BE CONTINUOUSLY VENTILATED AT ALL TIMES DURING WORK WITHIN THE MANHOLES.
- ZAYO BANDWIDTH, INC. AND/OR ITS REPRESENTATIVES, RESERVE THE RIGHT TO STOP CONSTRUCTION IF AT ANY TIME THEY DEEM THE WORK TO BE UNSAFE, INADEQUATE OR HAZARDOUS. WORK SHALL NOT BE RESUMED UNTIL AGREEABLE MEASURES HAVE BEEN TAKEN TO REMOVE ANY ISSUES.
- ANY AND ALL DAMAGE TO ASPHALT, CONCRETE PAVEMENT, CURBS, GUTTERS, SIDEWALKS, PAVERS, DRAINAGE DITCHES, EMBANKMENTS, SHRUBS, TREES, GRASS SOD, ETC., SHALL BE THE SOLE RESPONSIBILITY OF THE CONSTRUCTION CONTRACTOR AND SHALL BE IMMEDIATELY RESTORED TO THE ORIGINAL OR BETTER CONDITION AT THE EXPENSE OF THE CONSTRUCTION CONTRACTOR.
- THE CONSTRUCTION CONTRACTOR SHALL NOT START ANY WORK UNTIL AN APPROVED PERMIT OR WRITTEN APPROVAL FROM THE PROPERTY OWNER IS IN HIS OR HER POSSESSION.
- ALL TRENCHING WITHIN SITE COMPOUND TO BE HAND DUG.

1515 N Cleveland Ave
AIN0929A
Zayo Utility Project
Saint Paul, Minnesota

Zayo
BANDWIDTH
400 CENTENNIAL PARKWAY
STE. 200
LOUISVILLE, CO 80027

Plan Date: December 22nd, 2010

SPECIFICATIONS

Plans Prepared By:



11000 EAST 12TH STREET, SUITE 105
EAST BIRMGHAM, AL 35244
PHONE: 205-971-6925
FAX: 205-971-1196



Boardman Civil Engineering
A Land Surveying LLC
6602 ALBERTA CT.
BIRMGHAM, AL 35226
OFFICE: 205-6181
boardman@bsevl.com

REVISION BLOCK

Rev. No.	Description	Date
1	REV1: Rev. notes per SH	12-22-10

Project Number: 2010-082/AIN0929A

Sheet No.: C-2

1515 N Cleveland Ave
 AIN0929A
 Zayo Utility Project
 Saint Paul, Minnesota

Zayo
 BANDWIDTH
 400 CENTENNIAL PARKWAY
 STE. 200
 LOUISVILLE, CO 80027

Plan Date: December 22nd, 2010

**CONSTRUCTION
 DETAILS**

Plans Prepared By:



1 ELMHURST ROAD, SUITE 100
 EAST BRUNSWICK, NJ 08816
 PHONE: 732-911-6995
 FAX: 732-957-1198



Richard Chyl, Engineering
 & Land Surveying, LLC
 8002 ZILBEC CT
 LOUISVILLE, IN 46256
 OFFICE: 516-6131
 richard@rcc-engineering.com

REVISION BLOCK	
Rev. No.	Description
1	REV: Rev. post mounted demarc.
2	12-22-10

Project Number: 2010-082/AIN0929A

Sheet No. **C-3**

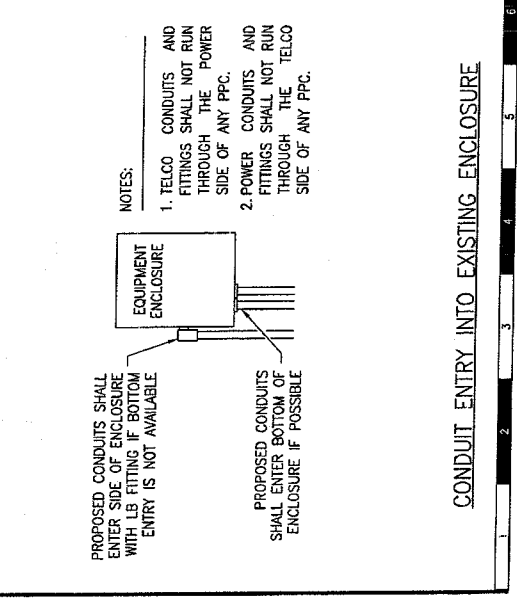
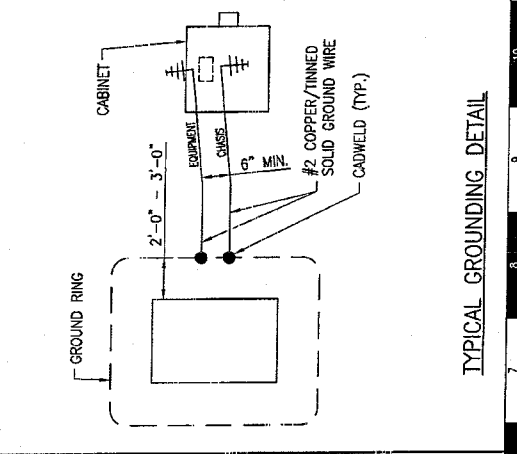
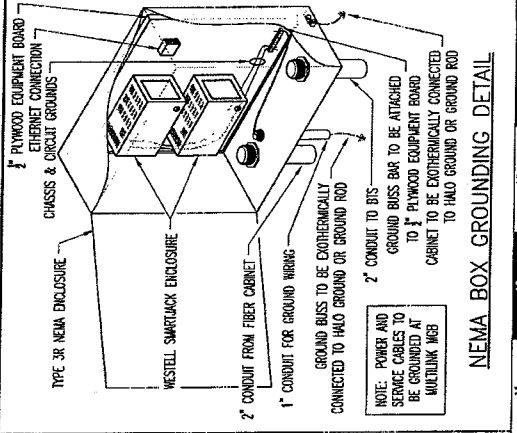
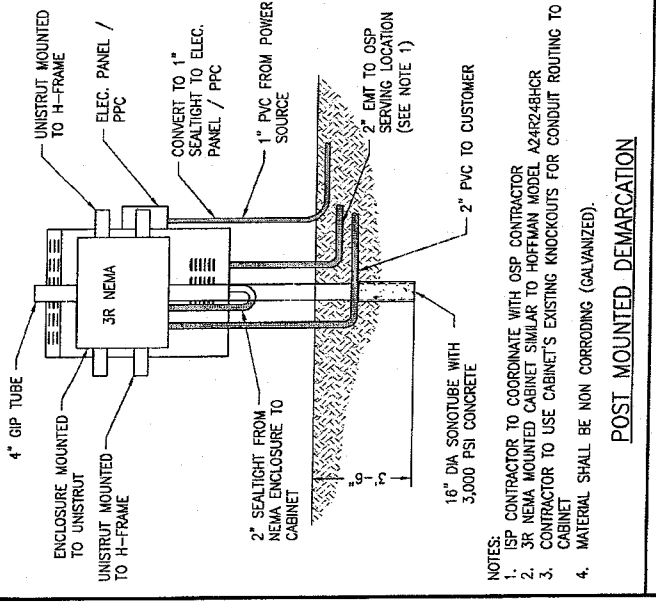
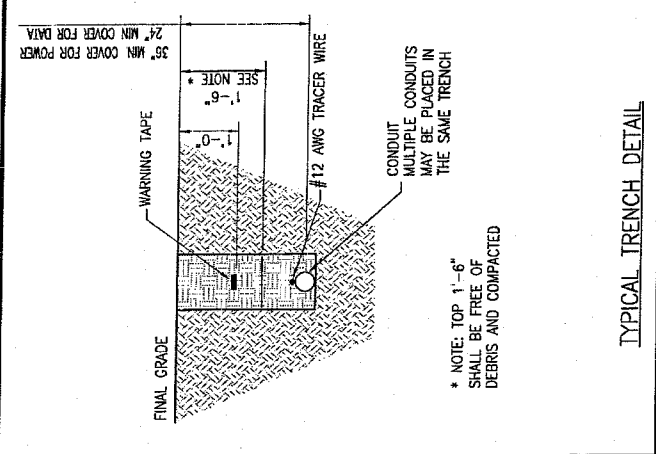
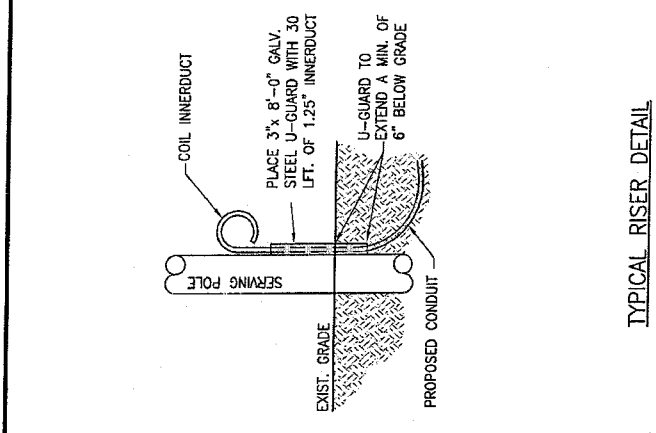

1515 N Cleveland Ave
AIN0929A
Zayo Utility Project
Saint Paul, Minnesota

ZAYO
BANDWIDTH
400 CENTENNIAL PARKWAY
STE. 200
LOUISVILLE, CO 80027

Plan Date: December 22nd, 2010

**CONSTRUCTION
DETAILS**

Plans Prepared By:

**Digital Systems
Engineering, LLC**
1809 KNOX ST.
DUBLIN, GA 31021
(478) 272-8851



REVISION BLOCK

Rev. No.	Description	Date

Project Number: 2010-082A/IN0929A

Sheet No.: **C-3A**

WATER TOWER PAINT SPECIFICATIONS

- a. Painting of all new items and repair of all damaged areas of the tower will be required. Surface preparation and painting requirements are as follows:
 - b. Under the direction of the Engineer, spot repair the tank and tower surfaces where the coating has been damaged by structural repairs and modifications, to an SSPC-SP-10 Near White Metal Blast Clean. This work includes all new items and at other areas damaged by structural repairs or modifications. Feather edges of existing coating, at spot blasted areas, using SSPC-SP-3 Power Tool Cleaning methods.
 - c. Before any primer or coating is applied, metal surfaces shall be completely dry, dust free, inspected, and approved by the Engineer.
 - d. No coating shall be permitted when the relative humidity is expected to exceed 85% or temperature is expected to drop below 40 degrees within 8 hours after the application of the coating. Proceed with surface preparation and coating application only when air and surface temperatures are above the manufacturer's recommended minimum surface temperature and below 100 degrees F, and surface temperature is at least 5 degrees above wet bulb air temperature reading. Coating shall not be applied to dusty, wet, or damp surfaces, and shall not be applied in rain, snow, fog, or mist. If working conditions are questionable, the Engineer shall make the decision and the Contractor shall accept the Engineer's interpretation as final and binding.
 - e. Prime coat must be applied within 8 hours of abrasive blasting.
 - f. Apply by brush one (1) additional coat of primer to insure a uniform coat of primer thoroughly worked into and around all seams, welds, bolt assemblies, plate overlap seams, and other irregularities in the surface.
 - g. Antennas, exterior coax cables, and exterior jumper cables to be painted to match existing tank color. All items attached directly to the tank, such as mounting brackets and supports, should be painted to match existing tank coating system and color. Cables may require scarification prior to coating.
 - h. Exposed coaxial cables: Solvent wipe all exposed cables, prior to priming with the recommended solvent. Prime the cables and jumper cables with 2 coats of X-I-M Coax Cable Binder & Sealer (Product No. 1135). Manufacturer's phone number is (800) 262-8469. After priming apply one finish coat to the cables as directed by the engineer.
 - i. If galvanized materials used, the galvanized surfaces must be solvent wiped and brush-blasted prior to coating.
 - j. Specifications apply to both shop and field coating.
 - k. Exterior surface spot repair and re-coating:
 - l. Spot prime and finish coat repaired areas as specified by manufacturer. The coating system shall match the existing coating system on the tower. The exterior primer shall be TNE MEC Series 90-1K97 Aromatic Polyurethane, Zinc Rich Primer 2.0 - 3.5 mils DFT. The DFT of the primer at any individual spot measurement location shall be 3.0 mils minimum. Intermediate coat shall be TNE MEC Series N140, at 4.0 - 6.0 mils DFT. The DFT of the primer plus intermediate coat at any individual spot measurement location shall be 5.0 mils minimum. Exterior finish coat shall be TNE MEC Series 1075 at 2.0 - 4.0 mils DFT. The total dry film thickness including the primer and the finish coat shall be 8.0 mils minimum - 13.5 mils with an average of 11.0 mils DFT. The minimum dry film thickness of the coating at any individual spot location shall be 8.0 mils. Color: The color on the tower exterior is 01 BR Warm Sun.
 - ii. Exterior coating shall be by brush and roller only.
 - l. Interior Dry surface spot repair and re-coating: Spot prime and finish coat repaired areas as specified by manufacturer. The coating system shall match the existing coating system on the tower. The exterior primer shall be TNE MEC Series 90-1K97 Aromatic Polyurethane, Zinc Rich Primer 2.0 - 3.5 mils DFT. The DFT of the primer at any individual spot measurement location shall be 3.0 mils minimum. Intermediate coat shall be TNE MEC Series N140, at 3.0 - 4.0 mils DFT. The DFT of the primer plus intermediate coat at any individual spot measurement location shall be 5.0 mils minimum. Exterior finish coat shall be TNE MEC Series N140 at 3.0 - 4.0 mils DFT. The total dry film thickness including the primer and the finish coat shall be 8.0 mils minimum - 11.5 mils with an average of 10.0 mils DFT. The minimum dry film thickness of the coating at any individual spot location shall be 8.0 mils. Color: The color on the tower interior dry shall match the existing color inside the tower.

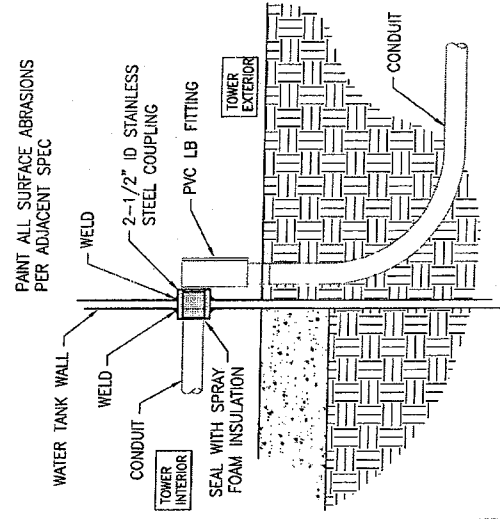

TOWER PENETRATION DETAIL

1515 N Cleveland Ave
 AIN0929A
 Zayo Utility Project
 Saint Paul, Minnesota

Zayo

BANDWIDTH
 400 CENTENNIAL PARKWAY
 STE. 200
 LOUISVILLE, CO 80027

Plan Date: February 23rd, 2011

SITE PLAN

Plans Prepared By:



Richard C. Williams
 Professional Engineer
 License No. 00105229
 8992 AIRPORT BLVD.
 SUITE 200
 WOODBRIDGE, NJ 07095
 PHONE: 732-661-1811
 EMAIL: rcw@triad-ia.com

Rev. No.	Description	Date
1	REV: Rev. per SH comments	12-22-10
2	REV: Add Zayo dimensions	2-23-11

Project Number: 2010-082/AIN0929A

Sheet No.: C-4

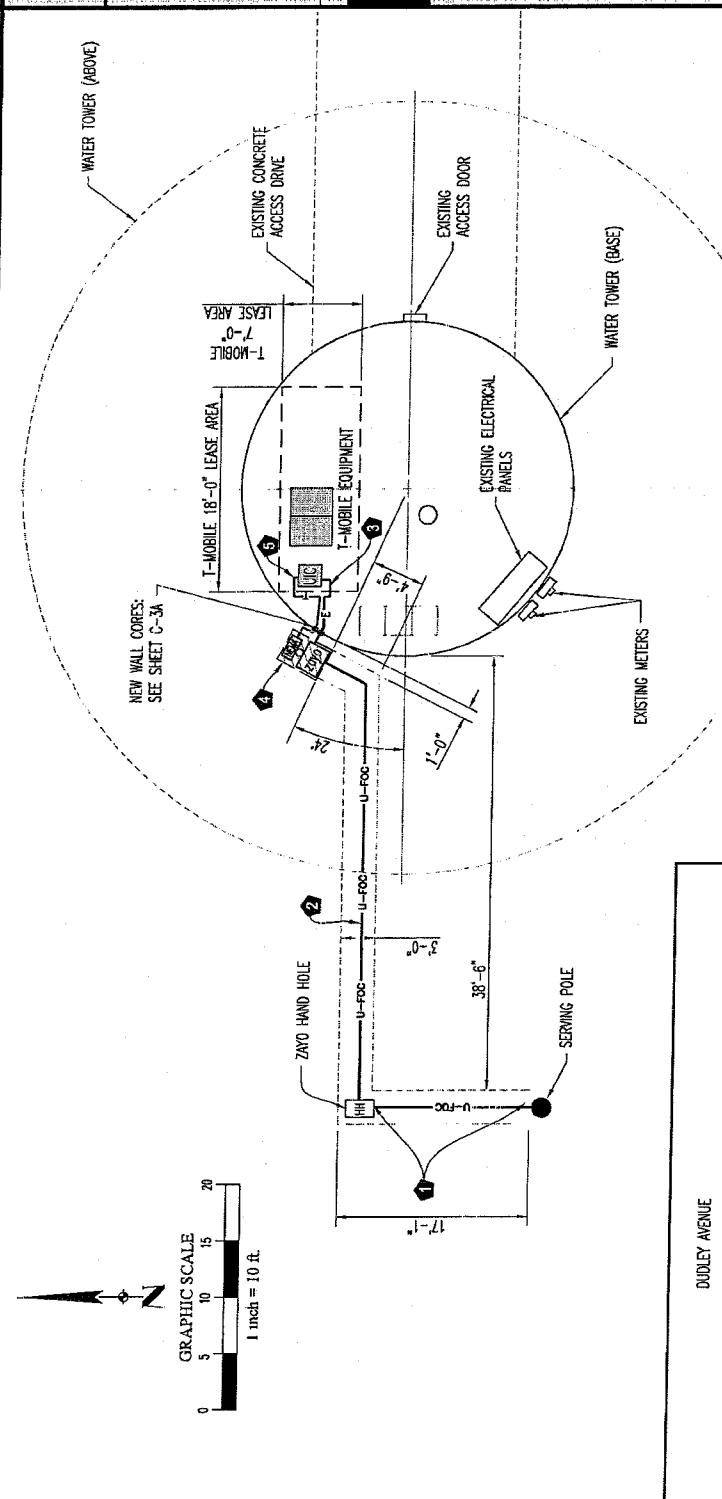

Site Construction Legend

ITEM	DESCRIPTION
1	Conduit 27' 5in. 80 PVC conduit for Zayo hand hole and serving pole. Conduit placement to be open trench. See other plans for USF routing.
2	Place 47' ft. of 2" Sch. 80 PVC conduit for Zayo fiber optic connection. Conduit to be stubbed 6" above grade and placed at a minimum depth of 24" below grade.
3	Place 13' (11' 0" EMT conduit for power. Conduit to be stubbed 6" above grade and placed at a minimum depth of 36" below grade. Conduit placement to be open trench. Add new well core to penetrate water tower. See detail sheet C-3A for well core details. Also, EMT conduit placed inside of tower to be secured to concrete floor with metal brackets and mechanical fasteners. Refer to Zayo Bandwidth Inside Plant/Site Location Manual for connections to power distribution panel and wiring connections.
4	Set Zayo cabinet and Type 3B NEMA box in 3' x 4' area (shown hatched). Connect fiber cabinet to NEMA box with 2" sealight conduit. Refer to Zayo Bandwidth Inside Plant/Site Location Manual for cabinet and wiring connections.
5	Place 16' (12' 0" EMT conduit to existing T-Mobile equipment for service. Conduit to be stubbed 6" above grade and placed at a minimum depth of 24" below grade. Conduit placement to be open trench. Conduit placed inside of tower to be secured to concrete floor with metal brackets and mechanical fasteners. Refer to Zayo Bandwidth Inside Plant/Site Location Manual for connections to power distribution panel and wiring connections.

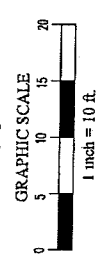
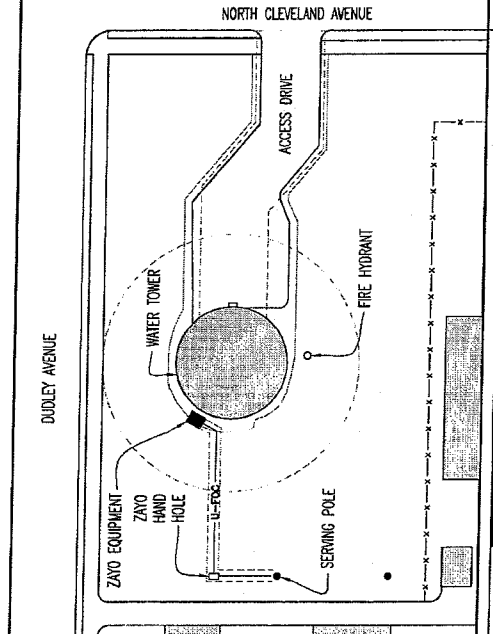

1515 N Cleveland Ave
 AIN0929A
 Zayo Utility Project
 Saint Paul, Minnesota

zayo
 BANDWIDTH
 400 CENTENNIAL PARKWAY
 STE. 200
 LOUISVILLE, CO 80027

Plan Date: October 4th, 2010

SITE PHOTOGRAPHS

Plans Prepared By:

Triad
 ENGINEERS ARCHITECTS

150 GIBNEY ROAD, SUITE 102
 ELKHART, IN 46516
 PHONE: 773-241-6985
 FAX: 773-257-1198

Brandt Civil Engineering & Land Surveying, LLC
 8902 Allbrook Ct.
 Indpls, IN 46256
 Office: 536-6181
 brandt@brandt-llc.com

REVISION BLOCK

Rev. No.	Description	Date

Project Number: 2010-082/A IN0929A

Sheet No.: **C-5**

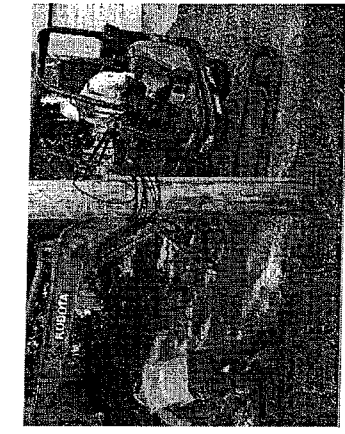

SERVING POLE

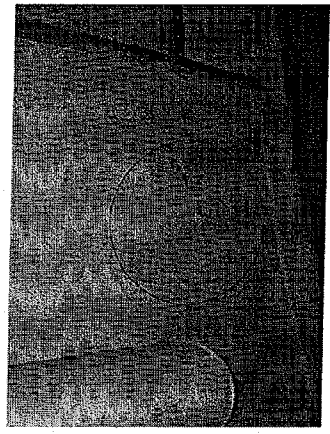

PENETRATION POINT - INSIDE
 (IN RED)

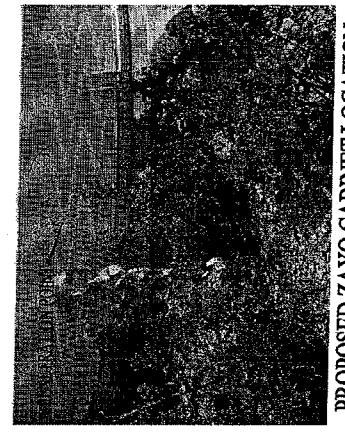

PROPOSED ZAYO CABINET LOCATION



ELECTRICAL METER

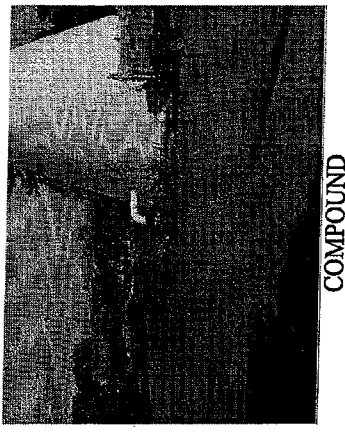

COMPOUND

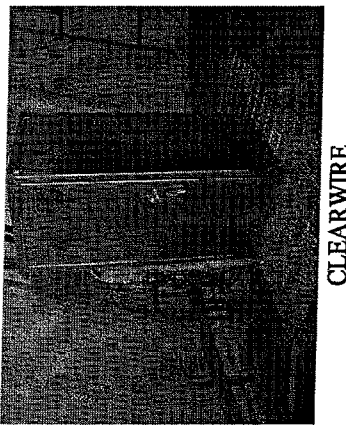

CLEARWIRES

EXHIBIT "B"

Zayo Bandwidth, LLC

Highland Water Tower No. 2

LESSEE FACILITIES

Brand	Part Number	Description	Quantity Used
Multilink	030-154-22	Pole Mount 19 RU Electronics Enclosure includes: DC Fans plus (1) ML-12-006-B-SPC-T3-002-11-12 loaded (includes:1 RU Fiber shelf, 1 duplex LC panel, 10-6432 (4) SM LC/UPC pigtails, (1) 70902K 1120-SSTA Aluminum 12 Single Fiber Splice Tray) plus (2) 10-6340 Duplex LC-LC SM 1 Meter UPC Cable Assemblies) plus (1) MCLQ-24-SM-C-BLK Loaded LDC SM Ceramic 6 Pack Panel 10-9709 plus (1) 35-079-10 Battery Heater Pad 10"x27" 120V 175W w/6' Power Cord. Upgraded Grounding per 030-154-22-SD	1
Multilink	744-720-P1	Pole Mount Bracket	1
Telect	EPPE-CAT6-24IDC	Telect CAT6 RJ to 110 panel (Cisco/Nokia)	1
Westell	B90311610	Westell DS1 NIU cards (Native and/or Sonet/T1)	8
Westell	DTWA528-04I2L4	Westell Smartjack Shelf (Native and/or Sonet/T1)	2
Universal	6644-1-222-01	Ethernet Demarc Biscuit-2 port surface mount	1
MK Powered	8G22F 77RC	MK Powered 12v, Gel valve-regulated lead acid batteries Terminal Type G 5/16" bolt & hex nut (T881) 8.99l 5.47w 9.24h	4
Hoffman	A24R248HCR	Hoffman Enclosure 24x24x8	1
Cisco	MWR-2941	Router/Switch	2
Accedian	AEN-1000-GE	EtherNID & MetroNID Demarcation Unit	2
		Miscellaneous power and ethernet cables to interconnect all of the above equipment together	
		2" conduit with 24 count armored fiberoptic cable from street, right of way, to cabinet	

EXHIBIT "B"

Exhibit “C”
Remote Facilities Access Plan
Saint Paul Regional Water Services (SPRWS)
Standard Operating Procedure (SOP)

See **CONTRACTOR PROCEDURES** at end of Exhibit “C”

INTENT:

SPRWS is dedicated to providing its employees with the safest work environment possible and to taking every reasonable precaution to ensure the safety of potable water delivered to our communities. This SOP provides conditions for persons with need to access SPRWS facilities outside the McCarrons Center facilities (Remote Facilities). It establishes procedures for access and responsibilities for both those wishing to enter remote facilities and those allowing such access.

SECURITY OF FACILITIES:

Persons with routine access to remote facilities include SPRWS staff, agents of entities leasing space, agents of various cities, and various law enforcement personnel. Other entities also have occasional access needs under the supervision of SPRWS staff. With so many persons having legitimate access needs, it is imperative that specific procedures be established to ensure that the highest level of security possible. As a result, the following procedures are established:

1.0 SITE ACCESS REQUIREMENTS

- 3.01 Request to access site required prior to entry. Important: Police will respond to electronic entrance detection if a call is not made to SPRWS prior to entry.

Note: all requests for entry to remote sites must be made through the Engine Room. Any other employee asked to allow entry to a remote site must inform the requester to call the Engine Room so that they can be cleared for entry.

- a) Routine and regularly scheduled

Whenever possible, authorized agencies that require repeated, routine access should schedule such access during normal business hours at least one day in advance by calling SPRWS Engine Room at 651-266-1660. The Engine Room Pumping Engineer will record the name of the agent and arrange for crew to meet agent on site and allow for access after checking for proper ID. Pumping Engineer will verify that agents requesting access are those that arranged for the access previously, and pass the authorized agents names to the field crew for verification in the field. If access is allowed, field crew will notify Engine Room that an entry to a site will occur.

EXHIBIT “C”

b) Emergencies

1. Contact Engine Room [651-266-1660].
2. a. Engine Room Pumping Engineer (PE II) will check against a list of authorized companies for each site to ensure that a particular company has reason to be on site.

b. If company is authorized, PE II will make arrangements with the Distribution after-hours Turn-On truck to allow for access at the site.

a. Distribution personnel will be responsible to verify the identity of the agent(s) and to monitor agent(s') activity at the site.
3. Under certain conditions, Distribution personnel may not be available, in which case PE IIs will use their best judgment to determine if there is another way to grant access to the agent, or to deny or delay access.

3.02 While at site:

- a) Authorized agents are required to perform their necessary work on the site in a manner that does not compromise site security. This includes, but is not limited to, securing all doors and gates before leaving the site.
- b) SPRWS employees will determine whether or not they will need to monitor the activity at the site. If SPRWS employee believes that the agent is not there for a legitimate business reason, the employee should get to a safe area and call 911 to have police confront the agent and remove them if necessary. In this event, SPRWS employee should also call the Engine Room to inform them of the proceedings.

3.03 Leaving site:

- a) Authorized agents must notify Engine Room [651-266-1660] when leaving the site.

2.0 IDENTIFICATION PROCEDURES

- 2.01 All SPRWS staff and personnel are issued a SPRWS photo identification card (ID card) at the McCarrons facility. This ID is to be displayed above the waist. Anyone purporting to be a SPRWS employee should be asked to display this ID card if it is not visible.
- 2.02 Contractors or agents seeking entrance to a remote facility are required to show a valid driver's license. SPRWS employee allowing them access will forward the name and phone number of the entrant to the Engine Room to confirm that access should be granted.

3.0 FACILITY LOCKS

- 1.01 All Remote Facilities will be secured with high-security locks utilizing high-security keys.

- a) Locks will be furnished and installed by SPRWS.
- b) No other locks are permitted, and all such other locks will be removed and disposed of.
- c) SPRWS may make some exceptions in cases where, for the convenience of SPRWS staff, contractor locks will be allowed to be “daisy-chained” onto a SPRWS facility. These exceptions will be on a case by case basis, and the decision to allow this will be made by SPRWS security officer.
- d) For sites that are undergoing construction, SPRWS will install construction locks and give contractors construction keys.

1.02 Issuance of Keys

- a) SPRWS staff who require access, as determined by the appropriate SPRWS division manager, will be issued keys. Such keys will be reduced to the lowest possible number.
 - 1. SPRWS staff are responsible for the safe keeping of keys issued to them.
 - 2. Repeated lost keys will be considered negligence and may result in corrective action and/or discipline by SPRWS management.
- b) Key audits will be conducted at least once each calendar year.
 - 1. Each SPRWS staff member, and each Authorized Agent, to whom SPRWS keys were issued will be required to sign a key Audit Statement acknowledging their continued possession of the key.
 - 2. Both Public and Private Agencies are responsible for the return of all keys and/or contractor keys issued to their agents who leave their employ or are no longer required by the Authorized Agency to access SPRWS facilities.
 - 3. Lost keys must be reported immediately to SPRWS by contacting the Engine Room [651-266-1660].
 - 4. Repeated losses may result in deposit requirements, as may be determined necessary by SPRWS staff.

4.0 SPRWS CONTACTS

4.01 Normal and emergency access after normal business hours:
PE II [651-266-1660].

If no answer, call Distribution Dispatch [651-266-6874].

CONTRACTOR PROCEDURES for entering SPRWS Water Tower Facilities

Routine Access:

- 1) Notify SPRWS Pumping Engineer [651-266-1660] of desired access at least 24 hours prior to accessing site. Pumping Engineer will verify that company has agreement to be on site, and if so will arrange for crew to meet contractor at designated time and place. Contractor must provide names of all employees that will access the site.
- 2) At time of arranged access, provide IDs (in the form of valid driver's licenses) for SPRWS field crew. If IDs match the names given to the Pumping Engineer, crew will provide access. If not, no access will be provided.
- 3) SPRWS field crew may accompany contractor while they are on site. If the crew does not accompany contractor, contractor must call the Pumping Engineer when they leave the site.

Emergency Access:

1. Notify SPRWS Engine Room [651-266-1660] of need to access site.
2. Engine Room Pumping Engineer will verify that contractor has an agreement to be on a particular site.
3. If contractor has agreement to be on site, and a reasonable explanation of the emergency is given, Pumping Engineer will arrange for a crew to meet contractor at the site.
4. Contractor will need to produce IDs and work orders.
5. If OK, crew will allow for access.
6. Repeated emergencies will be cause for SPRWS to bill the contractor or deny access.
7. Contractor will call Engine Room when leaving site.

Exhibit "D"
Technical Minimum Site Standards

- Not Applicable -

EXHIBIT "D"

Exhibit "E"
Memorandum of Lease Recording

Recording Requested by:

Zayo Bandwidth, LLC
400 Centennial Parkway
Suite 200
Louisville, CO 80027

When Recorded Mail to:

Zayo Bandwidth, LLC
400 Centennial Parkway
Suite 200
Louisville, CO 80027

(space above this line for Recorder's use only)

MEMORANDUM OF LEASE

THIS MEMORANDUM OF LEASE is entered into as of this _____ day of _____, 2011, by and between **BOARD OF WATER COMMISSIONERS OF THE CITY OF SAINT PAUL**, a municipal corporation under the laws of the State of Minnesota ("Lessor"), and **ZAYO BANDWIDTH, LLC, A DELAWARE LIMITED LIABILITY COMPANY** ("Lessee").

1. LEASE OF PREMISES. For the purpose of installing, operating, and maintaining a communication facility and other improvements, Lessor hereby leases to Lessee, and Lessee hereby leases from Lessor, certain premises located at 1515 North Cleveland Avenue, St. Paul, City of Saint Paul, County of Ramsey, State of Minnesota, and more particularly described in, and on the terms and conditions more particularly set forth in, that certain Communication Facility Lease dated _____ (the "Lease") by and between Lessor and Lessee, which terms and conditions are hereby incorporated by reference.
2. The Term of Lease shall terminate on December 31, 2016, subject to three (3) additional terms of five (5) years each.
3. The Lease provides in part the grant of easement for unrestricted rights of access and to electric and telephone facilities.
4. The subject property affected by the filing and recording of this Memorandum of Lease is described below:

Lots one (1) and two (2) all in Block one (1) of St. Anthony Park North, according to the record plat thereof on file and of record in the office of the Register of Deeds in and for the County of Ramsey, State of Minnesota.

Lessor:

Approved:

By _____
Stephen P. Schneider, General Manager
Saint Paul Regional Water Services

Approved as to form:

By _____
Assistant City Attorney

**BOARD OF WATER COMMISSIONERS
OF THE CITY OF SAINT PAUL**
FIN 41-6005521

By _____
Patrick Harris, President

By _____
Mollie Gagnelius, Secretary

CITY OF SAINT PAUL:

By _____
Paul Williams, Deputy Mayor

By _____
Shari Moore, City Clerk

By _____
Todd Hurley, Acting Director
Office of Financial Services

Lessee:

Approved:

By _____
Its Legal Counsel

ZAYO BANDWIDTH, LLC
Tax ID # _____

By _____

Its _____

ACKNOWLEDGEMENTS

BOARD OF WATER COMMISSIONERS OF THE CITY OF SAINT PAUL

STATE OF MINNESOTA)
)ss.
COUNTY OF RAMSEY)

On _____, 2011, before me, _____, Notary Public,
personally appeared Patrick Harris, President, Board of Water Commissioners of the City of Saint Paul, a Minnesota municipal corporation, on
behalf of the corporation.

Witness my hand and official seal.

Notary Public

STATE OF MINNESOTA)
)ss.
COUNTY OF RAMSEY)

On _____, 2011, before me, _____, Notary Public,
personally appeared Mollie Gagnelius, Secretary, Board of Water Commissioners of the City of Saint Paul, a Minnesota municipal corporation,
on behalf of the corporation.

Witness my hand and official seal.

Notary Public

CITY OF SAINT PAUL

STATE OF MINNESOTA)
)ss.
COUNTY OF RAMSEY)

On _____, 2011, before me, _____, Notary Public,
personally appeared Paul Williams, Deputy Mayor, on behalf of the Mayor of the City of Saint Paul, a Minnesota municipal corporation, on
behalf of the corporation.

Witness my hand and official seal.

Notary Public

STATE OF MINNESOTA)
)ss.
COUNTY OF RAMSEY)

On _____, 2011, before me, _____, Notary Public,
personally appeared Shari Moore, City Clerk, City of Saint Paul, a Minnesota municipal corporation, on behalf of the corporation.

Witness my hand and official seal.

Notary Public

STATE OF MINNESOTA)
)ss.
COUNTY OF RAMSEY)

On _____, 2011, before me, _____, Notary Public,
personally appeared Todd Hurley, Acting Director, Office of Financial Services of the City of Saint Paul, a Minnesota municipal corporation,
on behalf of the corporation.

Witness my hand and official seal.

Notary Public

LESSEE

STATE OF _____)
) ss.
COUNTY OF _____)

I certify that I know or have satisfactory evidence that _____ is the person who appeared before me, and said person acknowledged that he signed this instrument, on oath stated that he was authorized to execute the instrument and acknowledged it as the _____ of Zayo Bandwidth, LLC, A Delaware Limited Liability Company, to be the free and voluntary act of such party for the uses and purposes mentioned in the instrument.

Dated: _____

Witness my hand and official seal.

Notary Public