

**STATE OF MINNESOTA
DEPARTMENT OF TRANSPORTATION
AND
CITY OF SAINT PAUL
COOPERATIVE CONSTRUCTION
AGREEMENT**

State Project Number (SP):	<u>6215-114</u>	Estimated Amount Receivable
Trunk Highway Number (TH):	<u>51=125</u>	<u>\$817,707.15</u>
State Aid Project Number (SAP):	<u>164-010-088</u>	
Federal Project Number (FP):	<u>STBG 6224(098)</u>	
Lighting System Feed Point:	<u>CITY</u>	
Signal System ID:	<u>1735335</u>	
PCFS System ID:	<u>1736994</u>	

This Agreement is between the State of Minnesota, acting through its Commissioner of Transportation ("State"), and the City of Saint Paul acting through its City Council ("City").

Recitals

1. The State will perform bituminous mill and overlay, concrete paving, ADA improvements, and signal construction and other associated construction upon, along, and adjacent to Trunk Highway No. 51 (Snelling Avenue South) from Saint Clair Avenue to Grand Avenue according to State-prepared plans, specifications, and special provisions designated by the City and by the State as State Aid Project No. 164-010-088 and by the State as State project No. 6215-114 (TH 51=125) ("Project"); and
2. The City has requested the State include in its Project storm sewer and sanitary sewer construction; and
3. The City requests that it perform certain aspects of the construction engineering in connection with the sanitary sewer construction and the State concurs in that request; and
4. The City will participate in the costs of the Signal System, Signal System painting, lighting, storm sewer, sanitary sewer, and the Pedestrian Crosswalk Flasher System (PCFS) construction and associated construction engineering; and
5. Agreement No. 96266 between the parties will address the retaining wall maintenance within the boulevards in the Project area; and
6. Agreement No. 1055949 between the State and Saint Paul Regional Water Services will address utility relocations necessary for the Project area; and
7. Agreement No. 1054194 between the parties will address routine maintenance required for the Project area not covered under this Agreement; and
8. Agreement No. 1055599 between the parties will address the detour needed for this Project; and
9. Minnesota Statutes § 161.45, subdivision 2, allows for City-owned utility relocation to be included in a State construction contract, and payment by the City for such relocation according to applicable statutes and rules for utilities on trunk highways; and

10. Minnesota Statutes § 161.20, subdivision 2 authorizes the Commissioner of Transportation to make arrangements with and cooperate with any governmental authority for the purposes of constructing, maintaining, and improving the trunk highway system.

Agreement

1. Term of Agreement; Survival of Terms; Plans; Incorporation of Exhibits

- 1.1. *Effective Date.*** This Agreement will be effective on the date the State obtains all signatures required by Minnesota Statutes § 16C.05, subdivision 2.
- 1.2. *Expiration Date.*** This Agreement will expire when all obligations have been satisfactorily fulfilled.
- 1.3. *Survival of Terms.*** All clauses which impose obligations continuing in their nature and which must survive in order to give effect to their meaning will survive the expiration or termination of this Agreement, including, without limitation, the following clauses: 3. Maintenance by the City; 10. Liability; Worker Compensation Claims; 12. State Audits; 13. Government Data Practices; 14. Governing Law; Jurisdiction; Venue; and 16. Force Majeure; 17. Counterparts; 18. Electronic Signatures. The terms and conditions set forth in Article 4. Signal System and Emergency Vehicle Preemption System Operation and Maintenance and Article 5. Pedestrian Crosswalk Flasher System Power, Ownership, Operation, Maintenance and Compliance will survive the expiration of this Agreement but may be terminated by another Agreement between the parties.
- 1.4. *Plans, Specifications, and Special Provisions.*** Plans, specifications, and special provisions designated by the City and by the State as State Aid Project No. 164-010-088 and by the State as State project No. 6215-114 (TH 51=125) are on file in the office of the Commissioner of Transportation at St. Paul, Minnesota, and incorporated into this Agreement by reference ("Project Plans").
- 1.5. *Exhibits.*** The Preliminary Schedule "I" is on file in the office of the City of Saint Paul's Director of Public Works and attached and incorporated into this Agreement. Exhibit "A" – MnDOT BMP and City and MnDOT Storm Sewer - Ownership and Maintenance is attached and incorporated into this Agreement.

2. Construction by the State

- 2.1. *Contract Award.*** The State will advertise for bids and award a construction contract to the lowest responsible bidder according to the Project Plans.
- 2.2. *Direction, Supervision, and Inspection of Construction.***
- A. *Supervision and Inspection by the State.*** The State will direct and supervise all construction activities performed under the construction contract, and except as provided below, perform all construction engineering and inspection functions in connection with the contract construction. All contract construction will be performed according to the Project Plans.
- B. *Construction Engineering and Inspection by the City.*** The City will assign its City Engineer or other registered professional engineer to perform construction engineering in connection with the sanitary sewer construction. The engineer so assigned will act under the supervision and direction of the State and be responsible for construction inspection and associated documentation for said construction. The construction will be performed according to the Project Plans and recognized, and accepted practices and procedures as set forth in various State manuals, including Specifications No. 1601 through and including No. 1609 in the State's current "Standard Specifications for Construction". The City will furnish other personnel, services, supplies, and equipment needed to properly carry on the construction.

- i. **Documentation of Construction Costs.** At regular intervals after the State's contractor has started the sanitary sewer construction, the City will prepare partial estimates of the construction costs according to the terms of the construction contract and immediately submit the partial estimates to the State. The City will prepare the final estimate data for said construction and submit the final estimate to the State. Quantities listed on the partial and final estimates will be documented according to guidelines in the applicable documentation manual.
- ii. **Final Inspection of Construction.** Upon completion of the sanitary sewer construction, the City will advise the State whether or not said construction should be accepted by the State as being performed in a satisfactory manner. If the City recommends that the State not accept the construction, then the City will, as part of their recommendation, identify the specific defects in the construction and the reasons why it should not be accepted. Any recommendations made by the City are not binding on the State. The State will determine, after considering the City's recommendations, whether or not the construction has been properly performed and whether to accept or reject it.
- iii. **Inspection of Other City Participation Construction.** The remainder of the City participation construction covered under this Agreement will be open to inspection by the City. If the City believes the City participation construction covered under this Agreement has not been properly performed or that the construction is defective, the City will inform the State District Engineer's authorized representative in writing of those defects. Any recommendations made by the City are not binding on the State. The State will have the exclusive right to determine whether the State's contractor has satisfactorily performed the City participation construction covered under this Agreement.

2.3. **Plan Changes, Additional Construction, Etc.**

- A. The State will make changes in the Project Plans and contract construction, which may include the City participation construction covered under this Agreement and will enter into any necessary addenda and change orders with the State's contractor that are necessary to cause the contract construction to be performed and completed in a satisfactory manner. The State District Engineer's authorized representative will inform the appropriate City official of any proposed addenda and change orders to the construction contract that will affect the City participation construction covered under this Agreement.
- B. The City may request additional work or changes to the work in the plans as part of the construction contract. Such request will be made by an exchange of letter(s) with the State. If the State determines that the requested additional work or plan changes are necessary or desirable and can be accommodated without undue disruption to the Project, the State will cause the additional work or plan changes to be made.

2.4. **Satisfactory Completion of Contract.** The State will perform all other acts and functions necessary to cause the construction contract to be completed in a satisfactory manner.

2.5. **Permits.** The City will submit to the State's Utility Engineer an original permit application for all utilities owned by the City to be constructed hereunder that are upon and within the Trunk Highway Right-of-Way. Applications for permits will be made on State form "Application for Utility Permit On Trunk Highway Right-of-Way" (Form 2525).

2.6. **Utility Adjustments.** Adjustments to certain City-owned facilities, including but not limited to, valve boxes and frame and ring castings, may be performed by the State's contractor under the construction contract. The City will furnish the contractor with new units and/or parts for those in place City-owned facilities

when replacements are required and not covered by a contract pay item, without cost or expense to the State or the contractor, except for replacement of units and/or parts broken or damaged by the contractor.

3. Maintenance by the City

Upon completion of the Project, the City will provide the following without cost or expense to the State:

- 3.1. **Municipal Utilities.** Maintenance of any municipal-owned utilities construction, without cost or expense to the State. Exhibit "A" – MnDOT BMP and City and MnDOT Storm Sewer - Ownership and Maintenance will show the locations of storm sewer in the Project area and maintenance responsibilities for the City and the State. The State will maintain best management practices systems located within the Project limits.
- 3.2. **Lighting.** Maintenance and ownership of any lighting facilities construction. Maintenance of electrical lighting systems includes everything within the system, from the point of attachment to the power source or utility, to the last light on the feed point, including but not limited to re-lamping of lighting units or replacing of LED luminaires, repair or replacement of all damaged luminaire glassware, loose connections, luminaires when damaged or when ballasts fail, photoelectric control on luminaires, defective starter boards or drivers, damaged fuse holders, blown fuses, knocked down poles including wiring within the poles, damaged poles, pull boxes, underground wire, damaged foundations, equipment pad, installation of approved splices or replacement of wires, repair or extending of conduit, lighting cabinet maintenance including photoelectric cell, electrical distribution system, Gopher State One Call (GSOC) locates, and painting of poles and other equipment. The City will be responsible for the hook up cost and application to secure an adequate power supply to the service pad or pole and will pay all monthly electrical service expenses necessary to operate the lighting facility.
- 3.3. **Additional Drainage.** No party to this Agreement will drain any additional drainage volume into the storm sewer facilities constructed under the construction contract that was not included in the drainage for which the storm sewer facilities were designed, without first obtaining written permission to do so from the other party.

4. Signal System and EVP Systems Operation and Maintenance

Operation and maintenance responsibilities will be as follows for the Signal System and EVP System on TH 51 (Snelling Avenue South) at Saint Clair Avenue and for the interconnect on TH 51 (Snelling Avenue South) from Jefferson Avenue to Grand Avenue.

4.1. City Minor Maintenance Responsibilities

- A. **Power.** The City will be responsible for the hook-up cost and application to secure an adequate power supply to the service pads or poles and will pay all monthly electrical service expenses necessary to operate the Signal System, EVP Systems, and Interconnect.
- B. **Minor Signal System Maintenance.** The City will provide for the following, without cost to the State.
 - i. Maintain the signal pole mounted LED luminaires, including replacing the luminaires when necessary. The LED luminaire must be replaced when it fails or when light levels drop below recommended AASHTO levels for the installation.
 - ii. Replace the Signal System LED indications. Replacing LED indications consists of replacing each LED indication when it reaches end of life per the MnDOT Traffic Engineering Manual or fails or no longer meets Institute of Traffic Engineers (ITE) standards for light output.
 - iii. Clean the Signal System controller cabinet and service cabinet exteriors.

- iv. Clean and paint the Signal System and luminaire mast arm extensions.
- v. Paint and maintain the cross-street pedestrian crosswalk markings.

4.2. **City Major Maintenance Responsibilities**

- A. **Interconnect; Timing; Other Maintenance.** The City will maintain the Interconnect and signing, and perform all other Signal System, APS, and signal pole luminaire circuit maintenance without cost to the State. All Signal System timing will be determined by the City.
- B. **EVP Systems Operation.** The EVP Systems will be installed, operated, maintained, and removed according to the following conditions and requirements:
 - i. All maintenance of the EVP Systems will be done by City forces.
 - ii. Emitter units may be installed only on authorized emergency vehicles, as defined in Minnesota Statutes § 169.011, Subdivision 3. Authorized emergency vehicles may use emitter units only when responding to an emergency. The City will provide the State's District Engineer or their designated representative with a list of all vehicles with emitter units, if requested by the State.
 - iii. In the event the EVP Systems or its components are, in the opinion of the State, being misused or the conditions set forth in Paragraph ii. above are violated, and such misuse or violation continues after the City receives written notice from the State, the State may remove the EVP Systems. Upon removal of the EVP Systems pursuant to this Paragraph, all of its parts and components become the property of the State.
 - iv. All timing of the EVP Systems will be determined by the City.

4.3. **Right-of-Way Access.** Each party authorizes the other party to enter upon their respective public right-of-way to perform the maintenance activities described in this Agreement.

4.4. **Related Agreements.** This Agreement will supersede and terminate Agreement No. C270, between the parties, dated December 22, 1941, and any agreement and/or any signal system operation and maintenance terms of any agreement, between the parties, for the intersection of TH 51 (Snelling Avenue South) at Saint Clair Avenue and for the interconnect on TH 51 (Snelling Avenue South) from Jefferson Avenue to Grand Avenue.

5. **Pedestrian Crosswalk Flasher System Power, Ownership, Operation, Maintenance, and Compliance**

Power, ownership, operation, maintenance, and compliance responsibilities will be as follows for the PCFS, also known as the Rectangular Rapid Flashing Beacon System (per Agreement No. 06933) on Trunk Highway No. 51 (Snelling Avenue South) at Lincoln Avenue.

- 5.1. **Power.** The City will be responsible for the hook-up cost and application to secure an adequate power supply, if needed, and will service the pad or pole and will pay all monthly service expenses necessary to operate the PCFS.
- 5.2. **Ownership, Operation, and Maintenance.** Upon completion of this Project, the City will own the PCFS. The City will operate and maintain the PCFS and perform all Gopher State One Call locating, and be responsible for future system replacement, all at the City's cost and expense. The maintenance includes, but is not limited to snow, ice, and debris removal of the pedestrian landings and ramps, associated signing, crosswalk pavement markings, and lighting without cost or expense to the State. The City will perform all system maintenance in a timely manner.
- 5.3. **Compliance.** The City will be responsible for replacement or upgrades to meet compliance of current and future ADA requirements without cost or expense to the State. If the City fails to comply with the

maintenance terms or ADA requirements, or if a safety issue develops, the State may require the City to remove the PCFS or the State may remove it at the City's cost.

- 5.4. *Right-of-Way Access.*** The City will submit to the State form "Application for Miscellaneous Work on Trunk Highway Right-of-Way" (Form 1723) in order to perform TH 51 pedestrian crosswalk marking maintenance as described in Article 5.2.
- 5.5. *Related Agreements.*** This Agreement will supersede and terminate Agreement No. 06933, between the parties, dated December 5th, 2014.

6. Basis of City Cost

- 6.1. *Schedule "I".*** The Preliminary Schedule "I" includes anticipated City participation construction items and the construction engineering cost share covered under this Agreement and is based on engineer's estimated unit prices.
- 6.2. *City Participation Construction.*** The City will participate in the following at the percentages indicated. The construction includes the City's proportionate share of item costs for Mobilization, Field Office, and Traffic Control.
- A.** 50 Percent will be the City's rate of cost participation in all of the Signal System construction. The construction includes, but is not limited to, those construction items tabulated on Sheet No. 2 of the Preliminary Schedule "I".
 - B.** 100 Percent will be the City's rate of cost participation in all of the lighting and revise Signal System (RRFB) construction. The construction includes, but is not limited to, those construction items tabulated on Sheet No. 2 of the Preliminary Schedule "I".
 - C.** 100 Percent will be the City's rate of cost participation in all of the storm and sanitary sewer construction. The construction includes, but is not limited to, those construction items tabulated on Sheet No. 3 of the Preliminary Schedule "I".
- 6.3. *Signal System Painting.*** The City has requested Signal System painting as part of the Project construction. The City will pay a lump sum amount for the Signal System pole and mast arm painting construction as shown the Schedule "I".
- 6.4. *City Furnished Materials Credit.*** The City will furnish a Signal System cabinet (City Furnished Materials), according to the Project Plans, to operate the Signal System covered under this Agreement. The City will receive a lump sum amount credit from the State for the City Furnished Materials as shown in the Schedule "I".
- 6.5. *Construction Engineering Costs.*** The City will pay a construction engineering charge equal to 6 percent of the total sanitary sewer City participation construction covered under Article 6.2.C. The City will pay a construction engineering charge equal to 8 percent of the remainder of the City participation construction covered under this Agreement.
- 6.6. *Plan Changes, Additional Construction, Etc.*** The City will share in the costs of construction contract addenda and change orders that are necessary to complete the City participation construction covered under this Agreement, including any City requested additional work and plan changes.

The State reserves the right to invoice the City for the cost of any additional City requested work and plan changes, construction contract addenda, change orders, and associated construction engineering before the completion of the contract construction.

6.7. Liquidated Damages. All liquidated damages assessed the State's contractor in connection with the construction contract will result in a credit shared by each party in the same proportion as their total construction cost share covered under this Agreement is to the total contract construction cost before any deduction for liquidated damages.

7. City Cost and Payment by the City

7.1. City Cost. \$817,707.15 is the City's estimated share of the costs of the contract construction and the construction engineering cost share as shown in the Preliminary Schedule "I". The Preliminary Schedule "I" was prepared using anticipated construction items and estimated quantities and unit prices and may include any credits or lump sum costs. Upon award of the construction contract, the State will prepare a Revised Schedule "I" based on construction contract construction items, quantities, and unit prices, which will replace and supersede the Preliminary Schedule "I" as part of this Agreement.

7.2. Conditions of Payment. The City will pay the State the City's total estimated construction and construction engineering cost share, as shown in the Revised Schedule "I", after the following conditions have been met:

- A.** Execution of this Agreement and transmittal to the City, including a copy of the Revised Schedule "I".
- B.** The City's receipt of a written request from the State for the advancement of funds.

7.3. Acceptance of the City's Cost and Completed Construction. The computation by the State of the amount due from the City will be final, binding and conclusive. Acceptance by the State of the completed contract construction will be final, binding, and conclusive upon the City as to the satisfactory completion of the contract construction.

7.4. Final Payment by the City. Upon completion of all contract construction and upon computation of the final amount due the State's contractor, the State will prepare a Final Schedule "I" and submit a copy to the City. The Final Schedule "I" will be based on final quantities and include all City participation construction items and the construction engineering cost share covered under this Agreement. If the final cost of the City participation construction exceeds the amount of funds advanced by the City, the City will pay the difference to the State without interest. If the final cost of the City participation construction is less than the amount of funds advanced by the City, the State will refund the difference to the City without interest.

The State and the City waive claims for any payments or refunds less than \$5.00 according to Minnesota Statutes § 15.415.

8. Authorized Representatives

Each party's Authorized Representative is responsible for administering this Agreement and is authorized to give and receive any notice or demand required or permitted by this Agreement.

8.1. The State's Authorized Representative will be:

Name, Title:	Malaki Ruranika, Cooperative Agreements Engineer (or successor)
Address:	395 John Ireland Boulevard, Mailstop 682, St. Paul, MN 55155
Telephone:	(651) 366-4634
E-Mail:	malaki.ruranika@state.mn.us

8.2. The City's Authorized Representative will be:

Name, Title: Sean Kershaw, Director of Public Works (or successor)
 Address: 25 West 4th Street, 1500 City Hall Annex, Saint Paul, MN 55102
 Telephone: (651) 266-6100
 E-Mail: Sean.Kershaw@ci.stpaul.mn.us

9. Assignment; Amendments; Waiver; Contract Complete

- 9.1. *Assignment.*** No party may assign or transfer any rights or obligations under this Agreement without the prior consent of the other party and a written assignment agreement, executed and approved by the same parties who executed and approved this Agreement, or their successors in office. The foregoing does not prohibit the City from contracting with a third-party to perform City maintenance responsibilities covered under this Agreement.
- 9.2. *Amendments.*** Any amendment to this Agreement must be in writing and will not be effective until it has been executed and approved by the same parties who executed and approved the original Agreement, or their successors in office.
- 9.3. *Waiver.*** If a party fails to enforce any provision of this Agreement, that failure does not waive the provision or the party's right to subsequently enforce it.
- 9.4. *Contract Complete.*** This Agreement contains all prior negotiations and agreements between the State and the City. No other understanding regarding this Agreement, whether written or oral, may be used to bind either party.

10. Liability; Worker Compensation Claims

- 10.1.** Each party is responsible for its own acts, omissions, and the results thereof to the extent authorized by law and will not be responsible for the acts and omissions of others and the results thereof. Minnesota Statutes § 3.736 and other applicable law govern liability of the State. Minnesota Statutes Chapter 466 and other applicable law govern liability of the City.
- 10.2.** Each party is responsible for its own employees for any claims arising under the Workers Compensation Act.

11. Nondiscrimination

Provisions of Minnesota Statutes § 181.59 and of any applicable law relating to civil rights and discrimination are considered part of this Agreement.

12. State Audits

Under Minnesota Statutes § 16C.05, subdivision 5, the City's books, records, documents, accounting procedures, and practices relevant to this Agreement are subject to examination by the State and the State Auditor or Legislative Auditor, as appropriate, for a minimum of six years from the end of this Agreement.

13. Government Data Practices

The City and State must comply with the Minnesota Government Data Practices Act, Minnesota Statutes Chapter 13, as it applies to all data provided under this Agreement, and as it applies to all data created, collected, received, stored, used, maintained, or disseminated by the City under this Agreement. The civil remedies of Minnesota Statutes §13.08 apply to the release of the data referred to in this clause by either the City or the State.

14. Governing Law; Jurisdiction; Venue

Minnesota law governs the validity, interpretation, and enforcement of this Agreement. Venue for all legal proceedings arising out of this Agreement, or its breach, must be in the appropriate state or federal court with competent jurisdiction in Ramsey County, Minnesota.

15. Termination; Suspension

15.1. *By Mutual Agreement.* This Agreement may be terminated by mutual agreement of the parties.

15.2. *Termination for Insufficient Funding.* The State may immediately terminate this Agreement if it does not obtain funding from the Minnesota Legislature, or other funding source; or if funding cannot be continued at a level sufficient to allow for the performance of contract construction under the Project. Termination must be by written or fax notice to the City.

15.3. *Suspension.* In the event of a total or partial government shutdown, the State may suspend this Agreement and all work, activities, and performance of work authorized through this Agreement.

16. Force Majeure

No party will be responsible to the other for a failure to perform under this Agreement (or a delay in performance) if such failure or delay is due to a force majeure event. A force majeure event is an event beyond a party's reasonable control, including but not limited to, unusually severe weather, fire, floods, other acts of God, labor disputes, acts of war or terrorism, or public health emergencies.

17. Counterparts

The parties may sign this Agreement in counterparts, each of which constitutes an original, but all of which together constitute one instrument.

18. Electronic Signatures

The parties agree that the electronic signature of a party to this Agreement shall be as valid as an original signature of such party and shall be effective to bind such party to this Agreement. The parties further agree that any document (including this Agreement and any attachments or exhibits to this Agreement) containing, or to which there is affixed, an electronic signature shall be deemed (i) to be "written" or "in writing," (ii) to have been signed and (iii) to constitute a record established and maintained in the ordinary course of business and an original written record when printed from electronic files. For purposes hereof, "electronic signature" also means a manually signed original signature that is then transmitted by any electronic means, including without limitation a faxed version of an original signature or an electronically scanned and transmitted version (e.g., via PDF) of an original signature. Any party's failure to produce the original signature of any electronically transmitted signature shall not affect the enforceability of this Agreement.

(The remainder of this page has been intentionally left blank.)

CITY OF SAINT PAUL

The undersigned certify that they have lawfully executed this contract on behalf of the Governmental Unit as required by applicable charter provisions, resolutions, or ordinances.

Recommended for Approval:

By: _____
(Director of Public Works)

Approved as to form and execution:

By: _____
(Assistant City Attorney)

By: _____
(Mayor)

Date: _____

By: _____
(Director of Financial Services)

Date: _____

DEPARTMENT OF TRANSPORTATION

Recommended for Approval:

By: _____
(District Engineer)

Date: _____

Approved:

By: _____
(State Design Engineer)

Date: _____

COMMISSIONER OF ADMINISTRATION

By: _____
(With Delegated Authority)

Date: _____

INCLUDE COPY OF RESOLUTION APPROVING THE AGREEMENT AND AUTHORIZING ITS EXECUTION.

PRELIMINARY SCHEDULE "I"

Agreement No. 1055042

City of Saint Paul

SP 6215-114 (TH 51=125)

Preliminary: May 9, 2024

SAP 164-010-088

FP STBG 6224(098)

bituminous mill and overlay, concrete paving, ADA improvements, and signal construction to start approximately July 2024 under State Contract No. _____ with _____ located on Trunk Highway No. 51 (Snelling Avenue South) from Saint Clair Avenue to Grand Avenue

CITY COST PARTICIPATION

		TOTALS
SAP 164-010-088 Signal System Work Items From Sheet No. 2	229,772.79	
SAP 164-010-088 Lighting And PCFS Revision Work Items From Sheet No. 3	203,411.78	
Storm Sewer Work Items From Sheet No. 3	208,180.45	
Subtotal		641,365.02
Construction Engineering (8%)	51,309.20	
Total Cost for Signal System, Lighting, and PCFS Revision (Construction + Construction Engineering)		692,674.22
Sanitary Sewer Work Items From Sheet No. 3	141,742.97	
Construction Engineering (6%)	8,504.58	
Total Cost for Sanitary Sewer (Construction + Construction Engineering)		150,247.55
Total City Cost		\$842,921.78
(2) State Cost for City Furnished Materials From Sheet No. 3		(\$25,214.63)
(3) Total City Cost (less City Furnished Materials Credit)		\$817,707.15

(1) Signal System Pole and Mast Arm Painting will be a lump sum amount based on 50 percent of the total cost

(2) State Cost for City Furnished Materials is shown as a credit to the City

(3) Amount of advance payment as described in Article 7 of the Agreement (estimated amount)

ITEM NUMBER	SP 6215-114 AND SAP 164-010-088 WORK ITEM	UNIT	QUANTITY	UNIT PRICE	COST (1)
2021.501	MOBILIZATION	LUMP SUM	0.13	332,094.70	43,172.31
2031.502	FIELD OFFICE	EACH	0.13	43,819.04	5,696.48
2563.601	TRAFFIC CONTROL	LUMP SUM	0.13	166,047.35	21,586.16
2565.501	EMERGENCY VEHICLE PREEMPTION SYSTEM	LUMP SUM	1.00	5,315.98	5,315.98
2565.501	TRAFFIC CONTROL INTERCONNECT	LUMP SUM	1.00	20,182.77	20,182.77
2565.516	TRAFFIC CONTROL SIGNAL SYSTEM	SYSTEM	1.00	363,591.90	363,591.90
				TOTAL	\$459,545.59
		(1) 50% STATE		\$229,772.79	
		40.71% FEDERAL		\$187,081.01	
		9.29% STATE MATCH		\$42,691.79	
		50% CITY (STATE AID)		\$229,772.79	

(2) 100% CITY (STATE AID FUNDS)

(P) = PLAN QUANTITY

ITEM NUMBER	SP 6215-114 AND SAP 164-010-088 WORK ITEM	UNIT	QUANTITY	UNIT PRICE	COST (2)
2021.501	MOBILIZATION	LUMP SUM	0.05	332,094.70	16,604.74
2031.502	FIELD OFFICE	EACH	0.05	43,819.04	2,190.95
2104.602	REMOVE SIGN SPECIAL	EACH	18.00	85.82	1,544.76
2104.602	SALVAGE SIGN SPECIAL	EACH	19.00	46.67	886.73
2545.502	LIGHT FOUNDATION DESIGN SPECIAL	EACH	2.00	1,327.82	2,655.63
2545.502	HANDHOLE	EACH	8.00	2,352.50	18,819.99
2545.503	1.5" NON-METALLIC CONDUIT	LIN FT	2,550.00	22.71	57,918.15
2545.503	UNDERGROUND WIRE 1/C 8 AWG	LIN FT	7,650.00	4.54	34,750.89
2545.503	UNDERGROUND WIRE 1/C 10 AWG	LIN FT	2,550.00	3.41	8,687.72
2545.602	ADJUST HANDHOLE	EACH	9.00	1,022.09	9,198.81
2563.601	TRAFFIC CONTROL	LUMP SUM	0.05	166,047.35	8,302.37
2564.602	INSTSL SIGN SPECIAL	EACH	18.00	413.30	7,439.40
2564.618	SIGN SPECIAL	SQ FT	31.00	65.03	2,015.93

PLOTTED/REVISED: 2-APR-2024

DISTRICT #: Metro
PLOT NAME: d6215114_dr1
PATH & FILENAME: Projects\DM_R05\051\62151114\Design\PlanSheets\drainage plan and profile\d6215114_dr1.dgn

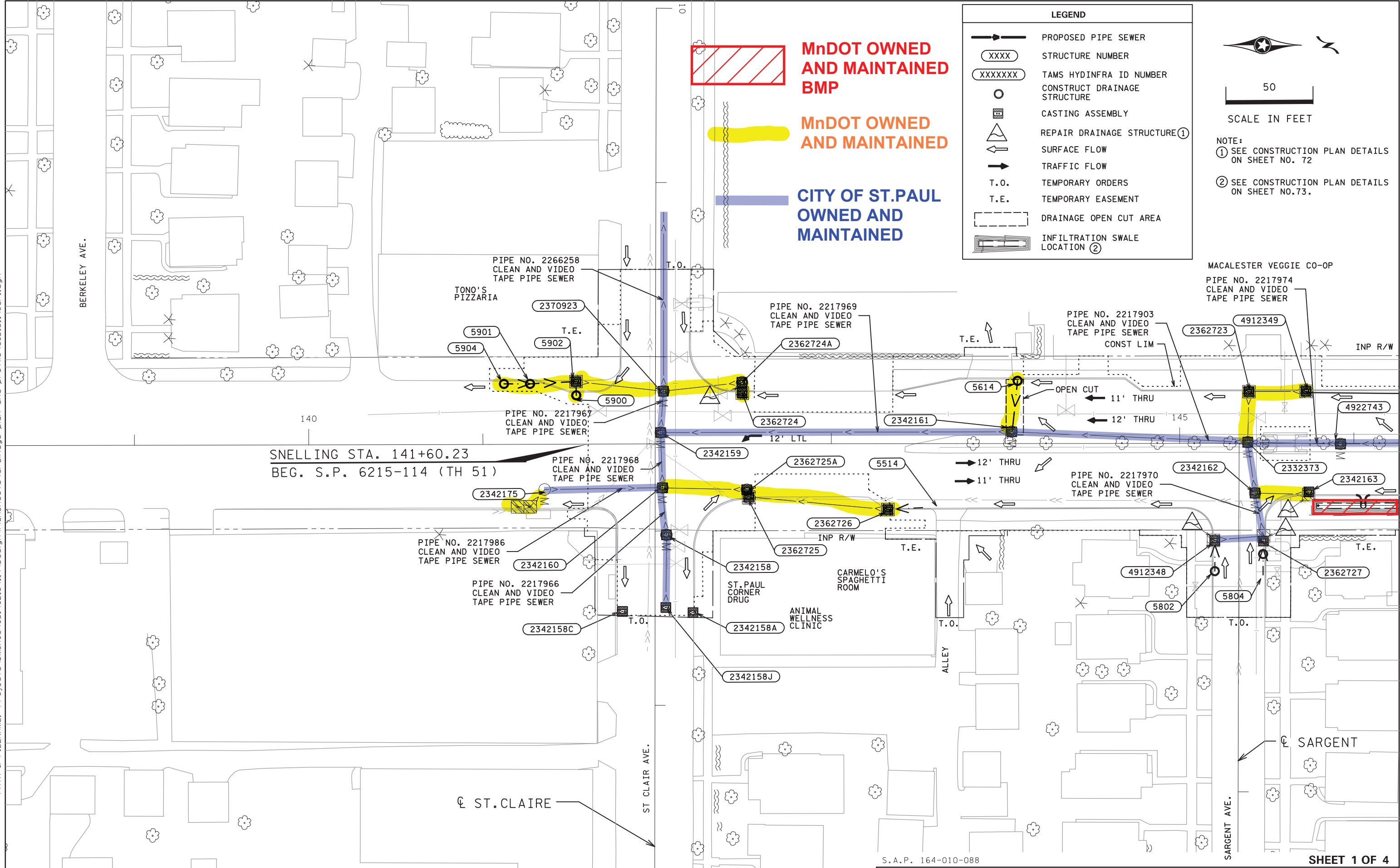

DRAINAGE PLANS

PLOTTED/REVISED: 2-APR-2024







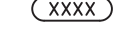
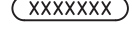

DISTRICT #: Metro
PLOT NAME: d6215114.dr2
PATH & FILENAME: Projects\DM_R05\051\6215114\Design\PlanSheets\drainage plan and profile\d6215114_dr1.dgn

 **MnDOT OWNED AND MAINTAINED BMP**

 **MnDOT OWNED AND MAINTAINED**

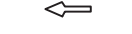
MACALESTER STADIUM

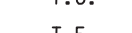
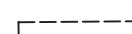
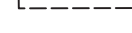
 **CITY OF ST. PAUL OWNED AND MAINTAINED**

LEGEND	
	PROPOSED PIPE SEWER
	STRUCTURE NUMBER
	TAMS HYDINFRA ID NUMBER
	CONSTRUCT DRAINAGE STRUCTURE
	CASTING ASSEMBLY
	REPAIR DRAINAGE STRUCTURE ①
	SURFACE FLOW
	TRAFFIC FLOW
	TEMPORARY ORDERS
	TEMPORARY EASEMENT
	DRAINAGE OPEN CUT AREA
	INFILTRATION TRENCH LOCATION ② ③
	INFILTRATION SWALE LOCATION ②

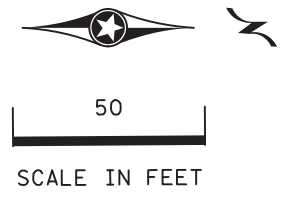

NOTE:
 ① SEE CONSTRUCTION PLAN DETAILS ON SHEET NO. 72
 ② SEE CONSTRUCTION PLAN DETAILS ON SHEET NO. 73.
 ③ SEE CONSTRUCTION PLAN DETAILS ON SHEET NO. 74.

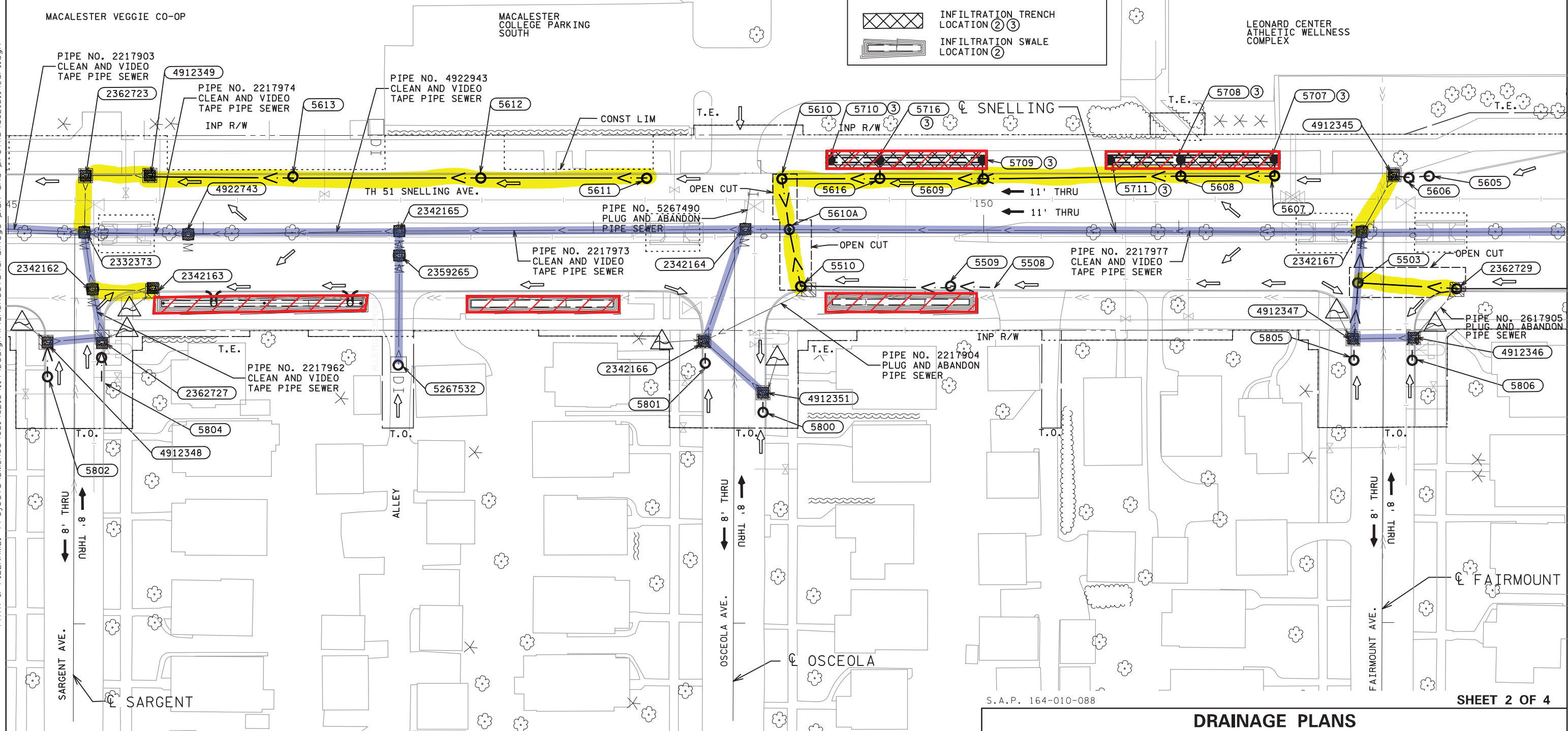

S.A.P. 164-010-088

SHEET 2 OF 4

DRAINAGE PLANS







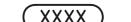

PLOTTED/REVISED: 2-APR-2024

DISTRICT #: Metro
PLOT NAME: d6215114.dr1
PATH & FILENAME: Projects\DM_R05\051\6215\114\Design\PlanSheets\drainage plan and profile\d6215114.dr1.dgn

 **MnDOT OWNED AND MAINTAINED BMP**

 **MnDOT OWNED AND MAINTAINED**

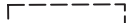
 **CITY OF ST. PAUL OWNED AND MAINTAINED**

LEGEND	
	PROPOSED PIPE SEWER
	STRUCTURE NUMBER
	TAMS HYDINFRA ID NUMBER
	CONSTRUCT DRAINAGE STRUCTURE
	CASTING ASSEMBLY
	REPAIR DRAINAGE STRUCTURE ①
	SURFACE FLOW
	TRAFFIC FLOW
T.O.	TEMPORARY ORDERS
T.E.	TEMPORARY EASEMENT
	DRAINAGE OPEN CUT AREA
	INFILTRATION SWALE LOCATION ②

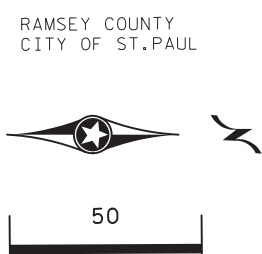

NOTE:
① SEE CONSTRUCTION PLAN DETAILS ON SHEET NO. 72
② SEE CONSTRUCTION PLAN DETAILS ON SHEET NO. 73.

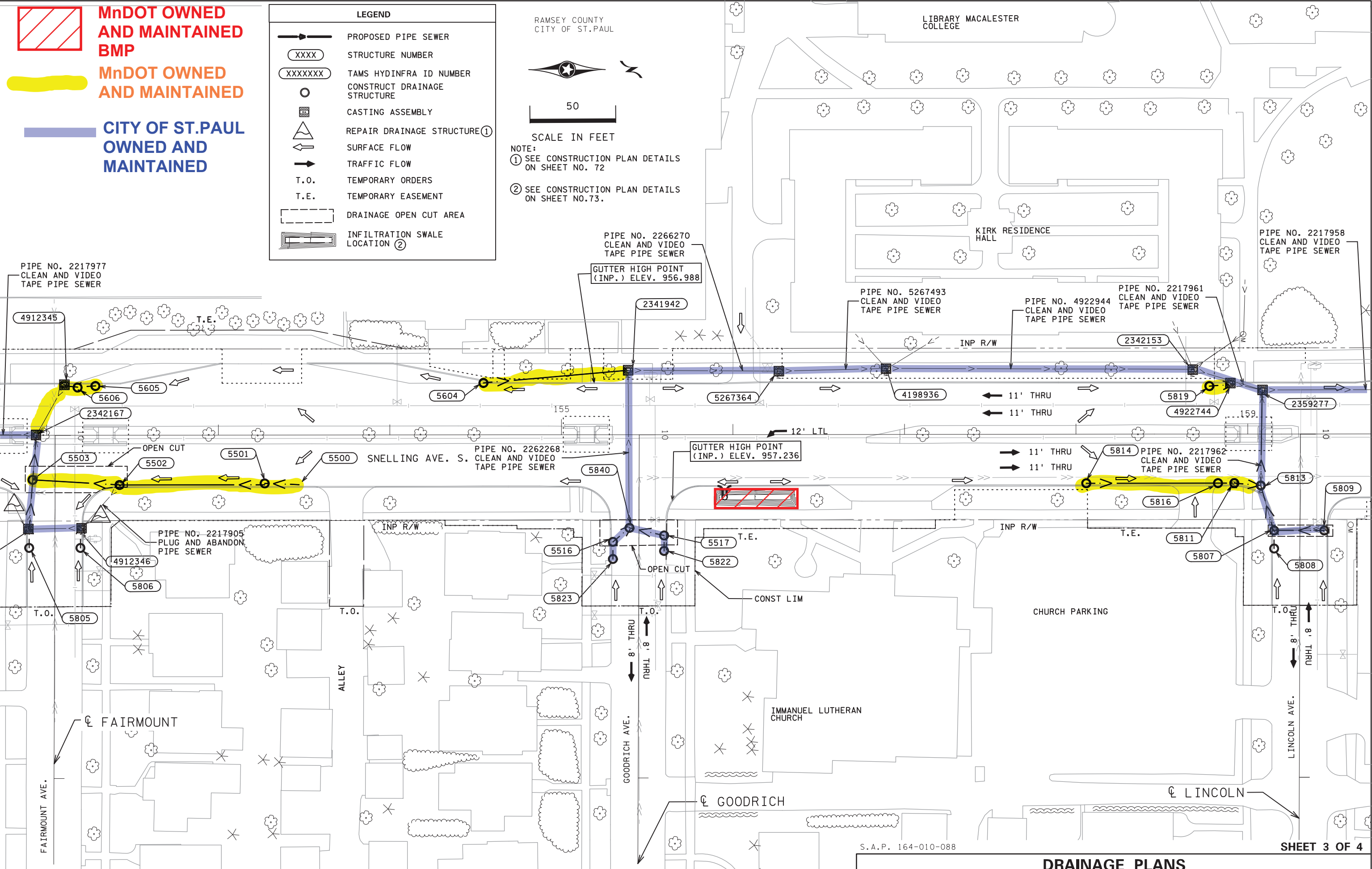

S.A.P. 164-010-088

SHEET 3 OF 4

DRAINAGE PLANS

PLOTTED/REVISED: 2-APR-2024

DISTRICT #: Metro
PLOT NAME: d6215114_dr4
PATH & FILENAME: Projects\DM_R05\051\6215114\Design\PlanSheets\drainage plan and profile\d6215114_dr1.dgn

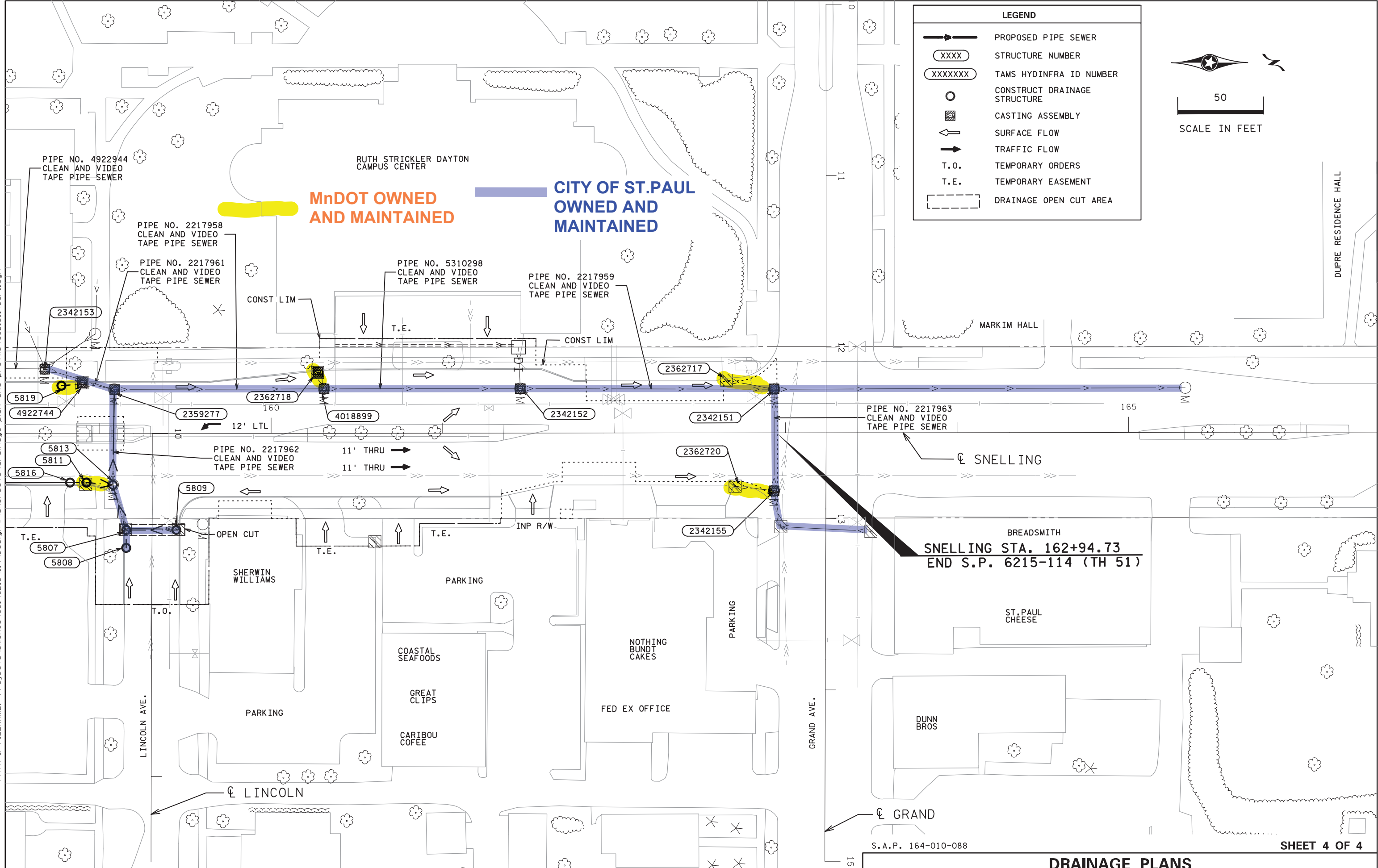

LEGEND	
	PROPOSED PIPE SEWER
	STRUCTURE NUMBER
	TAMS HYDINFRA ID NUMBER
	CONSTRUCT DRAINAGE STRUCTURE
	CASTING ASSEMBLY
	SURFACE FLOW
	TRAFFIC FLOW
T.O.	TEMPORARY ORDERS
T.E.	TEMPORARY EASEMENT
	DRAINAGE OPEN CUT AREA

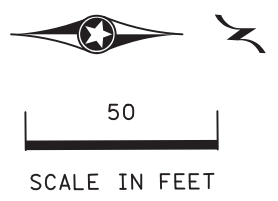

DRAWN BY: JM

CHECKED BY: PH

CERTIFIED BY Bryce Fossand
Digitally signed by Bryce Fossand
Date: 2024.04.02 15:47:45 -05'00'
LICENSED PROFESSIONAL ENGINEER

LIC. NO. 43444 DATE

STATE PROJ. NO. 6215-114 (T.H. 51) SHEET NO. 99 OF 113 SHEETS

DRAINAGE PLANS

CITY OF SAINT PAUL

RESOLUTION

IT IS RESOLVED that the City of Saint Paul enter into MnDOT Agreement No. 1055042 with the State of Minnesota, Department of Transportation for the following purposes:

To provide for payment by the City to the State of the City's share of the costs of the Signal System, Signal System painting, lighting, storm sewer, sanitary sewer, and the Pedestrian Crosswalk Flasher System (PCFS) construction and other associated construction to be performed upon, along, and adjacent to Trunk Highway No. 51 (Snelling Avenue South) from Saint Clair Avenue to Grand Avenue within the corporate City limits under State Aid Project No. 164-010-088 and State project No. 6215-114 (TH 51=125).

IT IS FURTHER RESOLVED that the Mayor and the _____
(Title)
are authorized to execute the Agreement and any amendments to the Agreement.

CERTIFICATION

I certify that the above Resolution is an accurate copy of the Resolution adopted by the Council of the City of Saint Paul at an authorized meeting held on the _____ day of _____, 2024, as shown by the minutes of the meeting in my possession.

Subscribed and sworn to me this _____ day of _____, 2024
Notary Public _____
My Commission Expires _____

_____ (Signature)
_____ (Type or Print Name)
_____ (Title)